



Installation Instructions

CONTENTS

	Page
SAFETY CONSIDERATIONS	1
ACOUSTICAL CONSIDERATIONS	2
Location	2
Ductwork	2
Acoustic Insulation	2
INSTALLATION	3-35
Step 1 — Provide Unit Support	3
• ROOF CURB	
• ALTERNATE UNIT SUPPORT	
Step 2 — Rig and Place Unit	3
• POSITIONING	
• ROOF MOUNT	
Step 3 — Field Fabricate Ductwork	3
Step 4 — Make Unit Duct Connections	3
• 50A2, A3, A6, AND A7 UNITS	
• 50A4, A5, A8, AND A9 UNITS	
Step 5 — Trap Condensate Drain	21
Step 6 — Make Electrical Connections	21
• POWER WIRING	
• FIELD POWER SUPPLY	
• FIELD CONTROL WIRING	
Step 7 — Make Outdoor-Air Inlet Adjustments	26
• ECONOMIZER AND MIXED OUTDOOR AIR DAMPER	
Step 8 — Position Power Exhaust/Barometric Relief Damper Hood	28
Step 9 — Route Static Pressure Sensors	28
• VAV DUCT PRESSURE TRANSDUCER	
• BUILDING PRESSURE TRANSDUCER	
Step 10 — Install All Accessories/Options	30
• FIELD-FABRICATED WIND BAFFLES	
Step 11 — Perform Field Modifications	32
• DUCTWORK	
BACnet Communication Option Wiring	32
• WIRING THE UPC OPEN CONTROLLER TO THE MS/TP NETWORK	
• MS/TP WIRING RECOMMENDATIONS	

SAFETY CONSIDERATIONS

Installation and servicing of air-conditioning equipment can be hazardous due to system pressure and electrical components. Only trained and qualified service personnel should install, repair, or service air-conditioning equipment.

Untrained personnel can perform the basic maintenance functions of cleaning coils and filters and replacing filters. All other operations should be performed by trained service personnel. When working on air-conditioning equipment, observe precautions in the literature, tags, and labels attached to the unit, and other safety precautions that may apply.

Follow all safety codes. Wear safety glasses and work gloves. Use quenching cloth for unbrazing operations. Have fire extinguishers available for all brazing operations.

⚠ WARNING

Before performing service or maintenance operations on unit, turn off main power switch to unit. Electrical shock could cause personal injury.

⚠ CAUTION

Puron refrigerant (R-410A) systems operate at higher pressures than standard R-22 systems. Do not use R-22 service equipment or components on Puron refrigerant equipment. If service equipment is not rated for Puron refrigerant, equipment damage or personal injury may result.

⚠ WARNING

1. Improper installation, adjustment, alteration, service, or maintenance can cause property damage, personal injury, or loss of life. Refer to the User's Information Manual provided with this unit for more details.
2. Do not store or use gasoline or other flammable vapors and liquids in the vicinity of this or any other appliance.

⚠ WARNING

DO NOT USE TORCH to remove any component. System contains oil and refrigerant under pressure.

To remove a component, wear protective gloves and goggles and proceed as follows:

- a. Shut off electrical power to unit.
- b. Recover refrigerant to relieve all pressure from system using both high-pressure and low pressure ports.
- c. Traces of vapor should be displaced with nitrogen and the work area should be well ventilated. Refrigerant in contact with an open flame produces toxic gases.
- d. Cut component connection tubing with tubing cutter and remove component from unit. Use a pan to catch any oil that may come out of the lines and as a gage for how much oil to add to the system.
- e. Carefully unsweat remaining tubing stubs when necessary. Oil can ignite when exposed to torch flame.

Failure to follow these procedures may result in personal injury or death.

⚠ CAUTION

DO NOT re-use compressor oil or any oil that has been exposed to the atmosphere. Dispose of oil per local codes and regulations. DO NOT leave refrigerant system open to air any longer than the actual time required to service the equipment. Seal circuits being serviced and charge with dry nitrogen to prevent oil contamination when timely repairs cannot be completed. Failure to follow these procedures may result in damage to equipment.

ACOUSTICAL CONSIDERATIONS

In order to minimize sound transmitted to the space, please conform to the following recommendations (see Fig. 1):

Location

- Avoid locating the unit above sound-sensitive areas. Instead, locate the unit above restrooms, storage areas, corridors, or other noise-tolerant areas.
- Avoid mounting the unit in the middle of large roof expanses between vertical supports. This will minimize the phenomenon known as roof bounce.
- Install the units close to vertical roof supports (columns or load bearing walls).
- Locate the units at least 25 ft away from critical areas. If this is not possible, the ductwork and ceiling structure should be acoustically treated.
- Consider the use of vibration isolators or an acoustic curb.

Ductwork

- Utilize flexible connectors between the unit and the supply and return ducts.

- Supply and return air main trunk ducts should be located over hallways and/or public areas.
- Provide trailing edge turning vanes in ductwork elbows and tees to reduce air turbulence.
- Make the ductwork as stiff as possible.
- Use round duct wherever possible because it is less noisy.
- Seal all penetrations around ductwork entering the space.
- Make sure that ceiling and wall contractors do not attach hangers or supports to ductwork.
- Provide as smooth and gradual transition as possible when connecting the rooftop unit discharge to the supply duct.
- If a ceiling plenum return is utilized, provide a return elbow or tee to eliminate line-of-sight noise to the space. Face the entrance of the return duct away from other adjacent units.

Acoustic Insulation

- Provide acoustic interior lining for first 20 ft of supply and return duct or until the first elbow is encountered. The elbow prevents line-of-sight transmission in the supply and return ducts.
- Install a double layer of 2-in. low density quilted fiberglass acoustical pad with a 1/8-in. barium-loaded vinyl facing on top of the roof deck before building insulation and roofing installation occur. Place the material inside the curb and for 4 to 8 ft beyond the unit perimeter, dependent upon unit size (larger units require a wider apron outside the curb). Openings in the pad should only be large enough for the supply and return ducts. An alternate approach is to use two layers of gypsum board with staggered seams in addition to the acoustical pad.

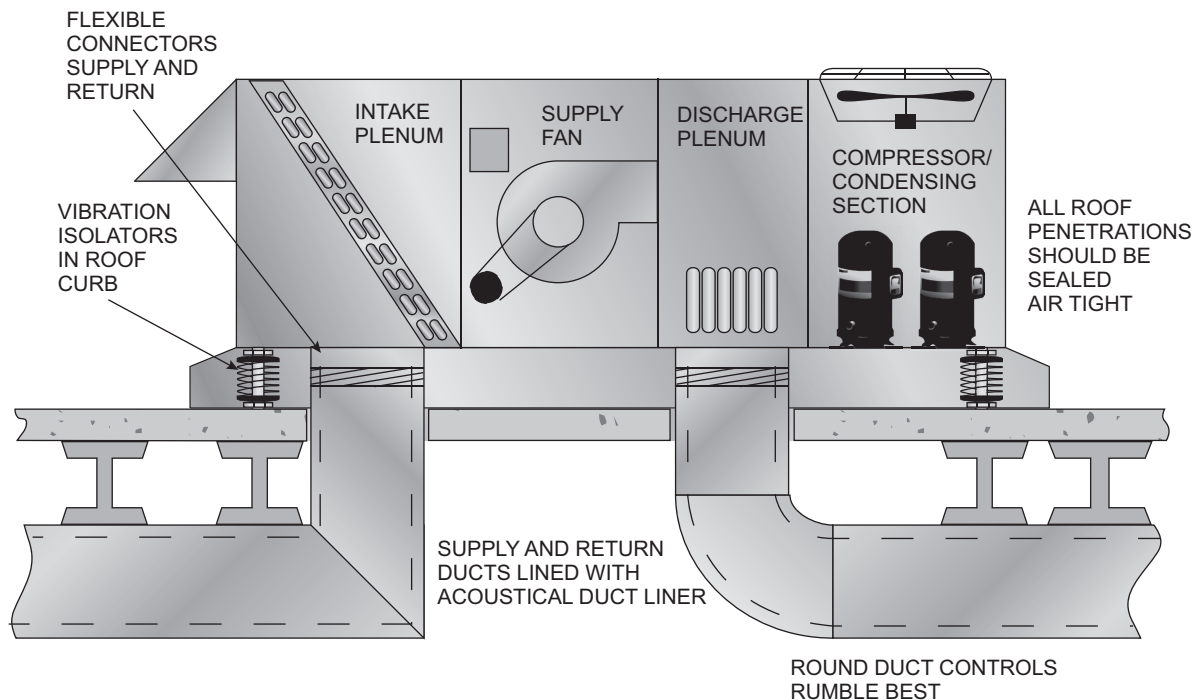

Fig. 1 — Acoustical Considerations

INSTALLATION

Step 1 — Provide Unit Support

⚠ CAUTION

1. All panels must be in place when rigging or damage to unit may occur.
2. Unit is not designed for handling by fork truck. Damage to unit may occur.

ROOF CURB — For vertical discharge units, assemble or install accessory roof curb in accordance with instructions shipped with this accessory. See Fig. 2-5. Install insulation, cant strips, roofing, and counter flashing as shown. Ductwork can be installed to roof curb before unit is set in place. Curb should be level. This is necessary to permit unit drain to function properly. Unit leveling tolerance is shown in Fig. 2-5. Refer to Accessory Roof Curb Installation Instructions for additional information as required. When accessory roof curb is used, unit may be installed on class A, B, or C roof covering material.

IMPORTANT: The gasketing of the unit to the roof curb is critical for a watertight seal. Install gasket with the roof curb as shown in Fig. 2-5. Improperly applied gasket can also result in air leaks and poor unit performance.

ALTERNATE UNIT SUPPORT — When the preferred curb or slab mount cannot be used, support unit with sleepers on perimeter, using unit curb support area. If sleepers cannot be used, support long sides of unit (refer to Fig. 6-14) with a minimum number of 4-in. x 4-in. pads spaced as follows: 50A020-035 units require 3 pads on each side; 50A040-050 units require 4 pads on each side; 50A060 units require 6 pads on each side. Unit may sag if supported by corners only.

Step 2 — Rig and Place Unit — Inspect unit for transportation damage. See Tables 1-6 for physical data and specifications. File any claim with transportation agency.

Do not drop unit; keep upright. Use spreader bars over unit to prevent sling or cable damage. This unit must be handled with a crane and cannot be handled by a fork truck. Level by using unit frame as a reference; leveling tolerance is shown in Fig. 2-5. See Fig. 15 for additional information. Unit operating weight is shown in Tables 2-5.

NOTE: On retrofit jobs, ductwork may be attached to the old unit instead of a roof curb. Be careful not to damage ductwork when removing old unit. Attach existing ductwork to roof curb instead of unit.

Four lifting lugs are provided on the unit base rails as shown in Fig. 6-14. Refer to rigging instructions on unit.

POSITIONING — Maintain clearance, per Fig. 6-14, around and above unit to provide minimum distance from combustible materials, proper airflow, and service access.

Do not install unit in an indoor location. Do not locate unit air inlets near exhaust vents or other sources of contaminated air.

Although unit is weatherproof, guard against water from higher level runoff and overhangs.

ROOF MOUNT — Check building codes for weight distribution requirements. See Fig. 15. Unit operating weight is shown in Tables 2-5.

Step 3 — Field Fabricate Ductwork — Secure all ducts to building structure. Use flexible duct connectors between unit and ducts as required. Insulate and weatherproof all external ductwork, joints, and roof openings with counter flashing and mastic in accordance with applicable codes.

NOTE: Due to width of the horizontal supply and return ductwork, provisions should be made for servicing of the outdoor air filters (i.e., catwalk over ductwork).

Ducts passing through an unconditioned space must be insulated and covered with a vapor barrier. Outlet grilles must not lie directly below unit discharge. The return duct must have a 90-degree elbow before opening into the building space if the unit is equipped with power exhaust.

To attach ductwork to roof curb, insert duct approximately 10 to 11 in. up into roof curb. Connect ductwork to 14-gauge roof curb material with sheet metal screws driven from inside the duct.

Follow AMCA (Air Movement and Control Association) guidelines relating to ductwork connections to the unit. These guidelines recommend a minimum 2½ equivalent duct diameters of straight duct connected to supply air inlet and outlet openings before any transitions, fittings, dampers, etc. Failure to adhere to these guidelines may result in system effects which can impact the unit's ability to achieve published performance.

⚠ WARNING

For vertical supply and return units, tools or parts could drop into ductwork and cause an injury. Install a 90-degree elbow turn in the supply and return ductwork between the unit and the conditioned space. If a 90-degree elbow cannot be installed, then a grille of sufficient strength and density should be installed to prevent objects from falling into the conditioned space.

Step 4 — Make Unit Duct Connections

50A2,A3,A6,A7 UNITS — Unit is shipped for thru-the-bottom duct connections. Field-fabricated ductwork should be attached to the roof curb. Supply and return duct dimensions are shown in Fig. 6, 7, 10, and 12. Air distribution is shown in Fig. 16. Refer to installation instructions shipped with roof curb for more information.

50A4,A5,A8,A9 UNITS — Remove shipping covers from supply and return air openings. Attach field-supplied ductwork to unit. Connect to the unit with a single duct for all supply openings and with a single duct for all return openings. Splitting of the airflow into branch ducts should not be done at the unit. Sufficient duct length should be used prior to branching to ensure the air temperatures are well mixed within the ductwork. See Fig. 8, 9, 11, and 13 for duct opening dimensions. Secure all ducts to building structure. Air distribution is shown in Fig. 8, 9, 11, 13, and 17. Verify the Outdoor Air Temperature (OAT) and Return Air Temperature (RAT) sensors as outlined in Fig. 18 can measure the OAT and RAT temperature sensors in the corresponding air streams. Relocate the sensor locations if needed.

Install accessory barometric relief or power exhaust in the field-fabricated return ductwork. Refer to Step 8 — Position Power Exhaust/Barometric Relief Damper Hood section on page 28 for more information.

Instructions continued on page 21.

- NOTES:**
1. Unless otherwise specified, all dimensions are to outside of part.
 2. Roof curb accessory CRRFCURB005A00 is shipped disassembled.
 3. All roof curb parts are to be 14 ga. galvanized steel.
 4. Units with electric heat must be installed with a 90 degree elbow on the supply duct prior to any supply take offs or branches.
 5. Dimensions in [] are in millimeters. All other dimensions are in inches.

NOTE:
TO PREVENT STANDING WATER IN THE DRAIN PAN OF THE INDOOR SECTION, AND THE HEAT EXCHANGERS UNIT CAN ONLY BE PITCHED AS SHOWN.

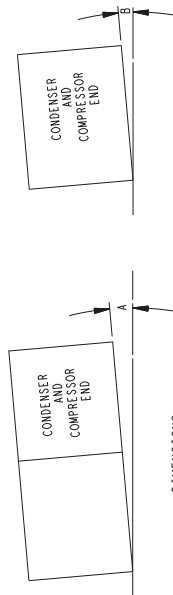

DIMENSIONS
(DEGREES AND INCHES)

DEG.	IN.	mm	DEG.	IN.	mm
1.0	2.9	73	.50	.75	19

UNIT LEVELING TOLERANCES
*FROM EDGE OF UNIT TO HORIZONTAL

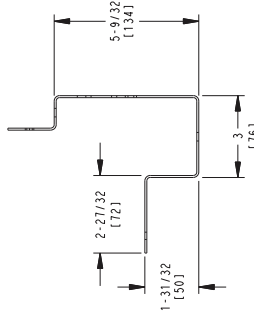
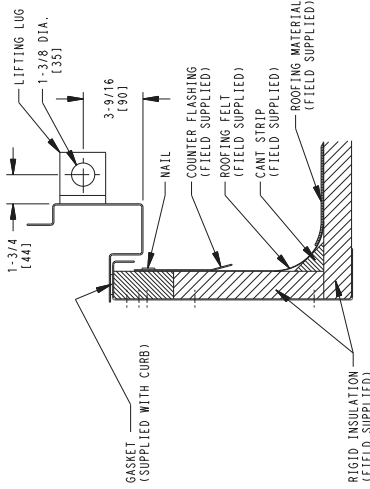

BASE RAIL CROSS SECTION
TYP 2 SIDES

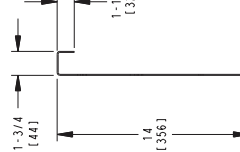

ROOF CURB CROSS SECTION
TYP 4 SIDES

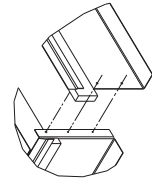

SEE DETAIL "Z"
ROOF CURB
SCALE 1:16

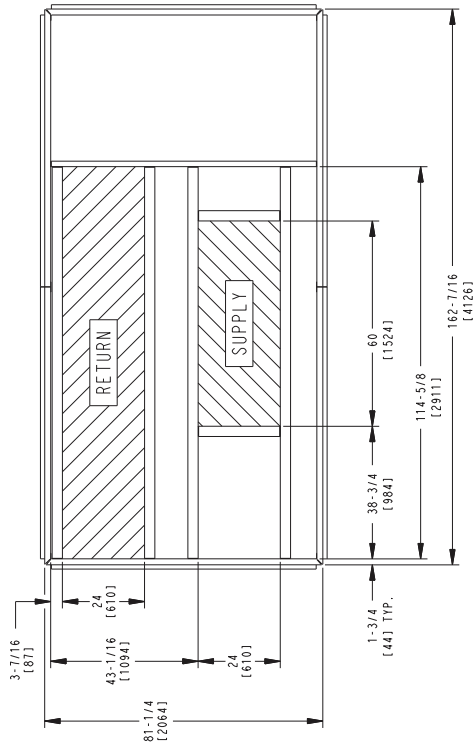

ROOF CURB DETAIL "A"
(ALL OTHERS)

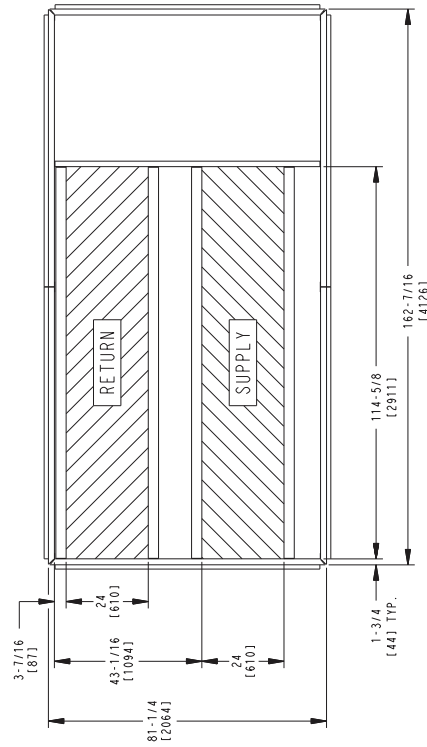

ROOF CURB DETAIL "B"
(48A2/A3/A6/A7-035 HIGH GAS HEAT ONLY)

DO NOT USE CROSSMOUNTS WITH 48A2/A3-035 HIGH GAS HEAT UNITS (SEE ROOF CURB DETAIL "B").

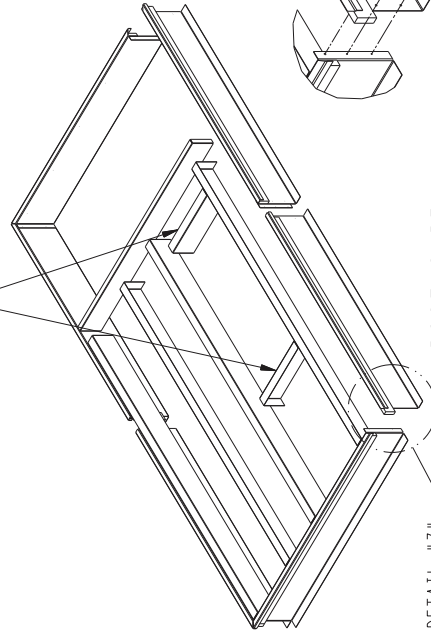
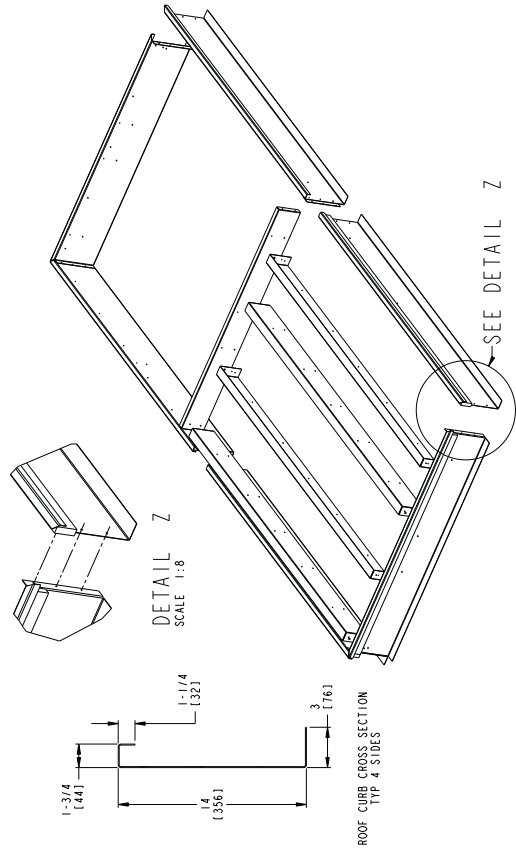
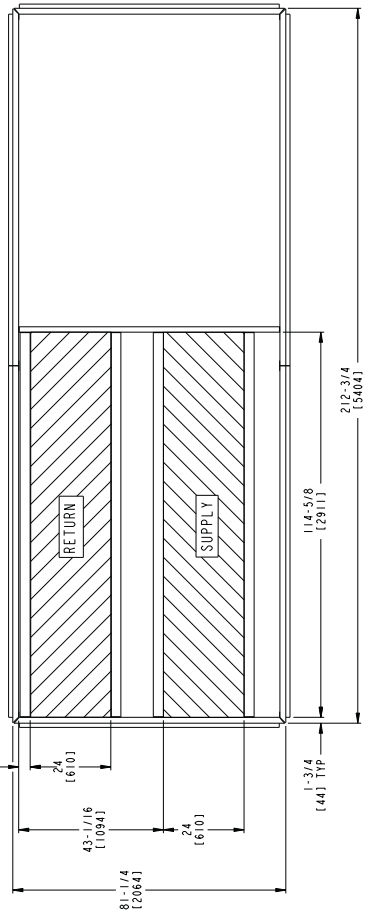
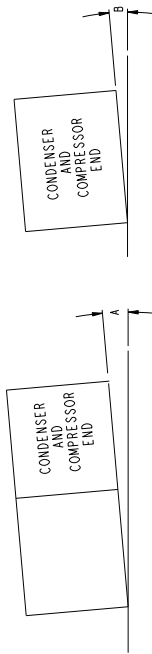

Fig. 2 — Roof Curb — 50A2,A3,A6,A7020-035 Units

- NOTES:**
1. Unless otherwise specified, all dimensions are to outside of part.
 2. Roof curb accessory CRFCURB006A00 is shipped disassembled.
 3. All outdoor parts are to be 14-gal. galvanized steel.
 4. Units with electric heat must be installed with a 90 degree elbow on the supply duct prior to any supply take offs or branches.
 5. Dimensions in [] are in millimeters. All other dimensions are in inches.



NOTE:
TO PREVENT STANDING WATER IN THE DRAIN PAN OF THE
INDOOR SECTION, AND THE HEAT EXCHANGERS
UNIT CAN ONLY BE PITCHED AS SHOWN.



DIMENSIONS
(DEGREES AND INCHES)

A		B	
DEG.	IN.	DEG.	IN.
T.0	2.9	.50	.75
			.19

UNIT LEVELING TOLERANCES
*FROM EDGE OF UNIT TO HORIZONTAL

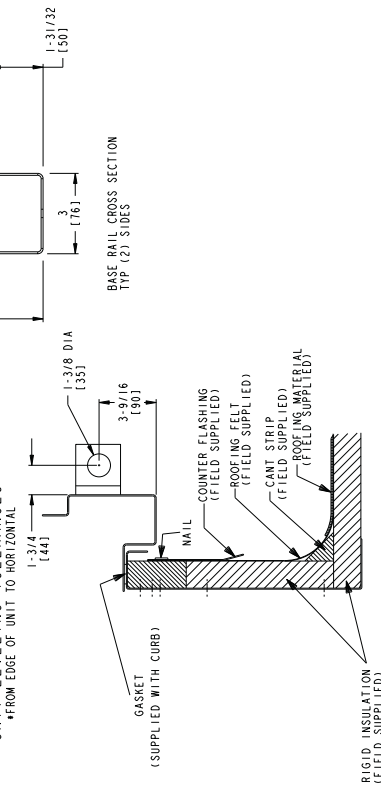

Fig. 3 — Roof Curb — 50A2,A3,A6,A7040-050 Units

- NOTES:
1. Unless otherwise specified, all dimensions are to outside of part.
 2. Roof curb accessory, CRRFCURB014A000 is shipped disassembled.
 3. All roof curb parts are to be 14 ga. galvanized steel.
 4. Units with electric heat must be installed with a 90 degree elbow on the supply duct prior to any supply take offs or branches.
 5. Dimensions in [] are in millimeters. All other dimensions are in inches.

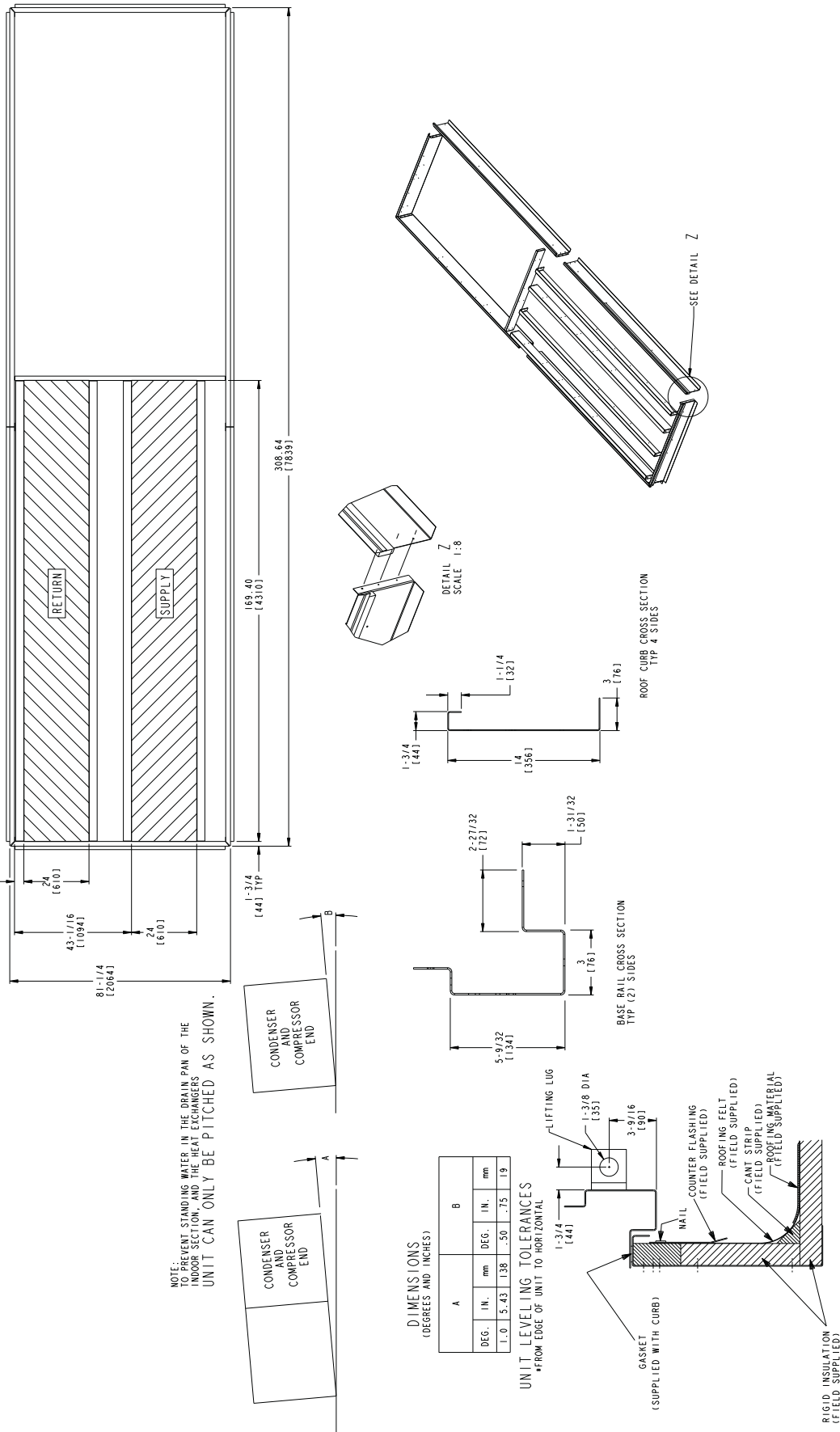
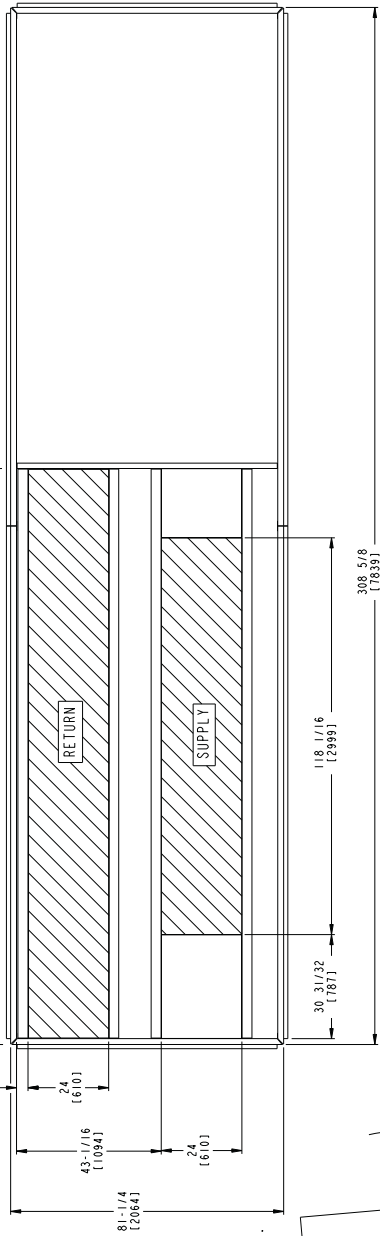
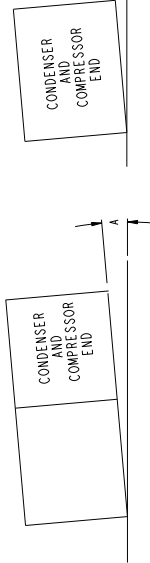

Fig. 4 — Roof Curb — 50A2, A3, A6, A7060 Units

- NOTES:
1. Unless otherwise specified, all dimensions are to outside of part.
 2. Roof curb accessory, CRFCURB009A00, is shipped disassembled.
 3. All roof curb parts are to be 14 ga. galvanized steel.
 4. Units with electric heat must be installed with a 90 degree elbow on the supply duct prior to any supply take offs or branches.
 5. Dimensions in [] are in millimeters. All other dimensions are in inches.



NOTE:
TO PREVENT STANDING WATER IN THE DRAIN PAN OF THE
INDOOR SECTION, AND THE HEAT EXCHANGERS
UNIT CAN ONLY BE PITCHED AS SHOWN.



DIMENSIONS
(DEGREES AND INCHES)

A		B	
DEG.	IN.	DEG.	IN.
1.0	5.43	.50	.75
	[138]		[19]

UNIT LEVELING TOLERANCES
*FROM EDGE OF UNIT TO HORIZONTAL

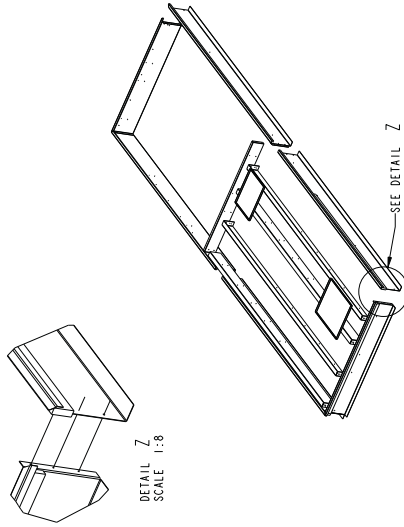
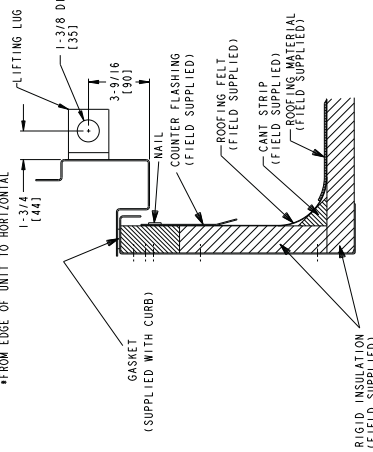
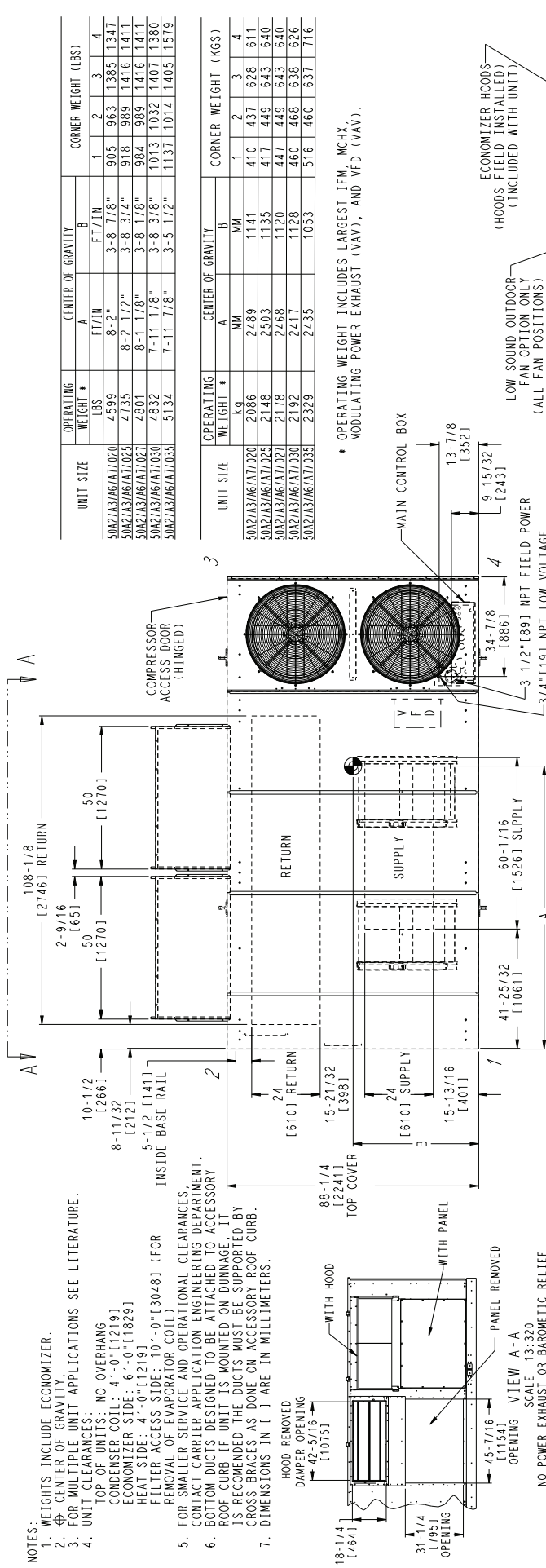

Fig. 5 — Reduced Supply Duct Opening — Roof Curb — 50A2,A3,A6,A7060 Units



UNIT SIZE	OPERATING WEIGHT *		CENTER OF GRAVITY		CORNER WEIGHT (LBS)			
	LBS	FT/IN	A	B	1	2	3	4
50A2/A3/A6/A7/020	4599	8-2"	3-8 7/8"	905	363	1385	1347	
50A2/A3/A6/A7/025	4735	8-2 1/2"	3-8 3/4"	918	389	1416	1411	
50A2/A3/A6/A7/027	4801	8-1 1/8"	3-8 1/8"	984	389	1416	1411	
50A2/A3/A6/A7/030	4832	7-11 1/8"	3-8 3/8"	1013	1032	1407	1380	
50A2/A3/A6/A7/035	5134	7-11 7/8"	3-5 1/2"	1137	1014	1405	1579	

UNIT SIZE	OPERATING WEIGHT *		CENTER OF GRAVITY		CORNER WEIGHT (KGS)			
	Kg	MM	A	B	1	2	3	4
50A2/A3/A6/A7/020	2086	2489	1141	410	437	628	611	
50A2/A3/A6/A7/025	2148	2503	1135	417	449	643	640	
50A2/A3/A6/A7/027	2178	2468	1120	447	449	643	640	
50A2/A3/A6/A7/030	2192	2417	1128	460	468	638	626	
50A2/A3/A6/A7/035	2329	2435	1053	516	460	637	716	

* OPERATING WEIGHT INCLUDES LARGEST IFM, MCHX, MODULATING POWER EXHAUST (VAV), AND VFD (VAV).

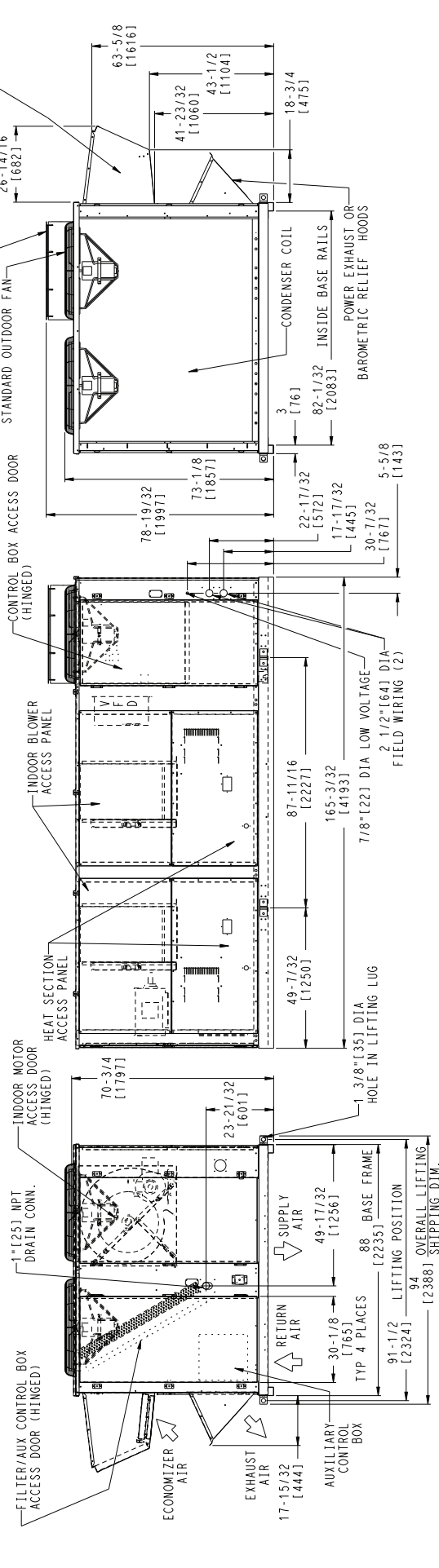

Fig. 6 — Base Unit Dimensions — 50A2,A3,A6,A7/020-035

- NOTES:
- WEIGHTS INCLUDE ECONOMIZER.
 - CENTER OF GRAVITY.
 - FOR MULTIPLE UNIT APPLICATIONS SEE LITERATURE.
 - UNIT CLEARANCES:
TOP OF UNITS: NO OVERHANG
CONDENSER COIL: 4'-0" [1219]
ECONOMIZER SIDE: 6'-0" [1829]
HEAT SIDE: 4'-0" [1219]
FILTER ACCESS SIDE: 10'-0" [3048] (FOR REMOVAL OF EVAPORATOR COIL)
FOR SMALLER SERVICE AND OPERATIONAL CLEARANCES, CONTACT CARRIER APPLICATION ENGINEERING DEPARTMENT.
BOTTOM DUCTS DESIGNED TO BE ATTACHED TO ACCESSORY ROOF CURB IF UNIT IS MOUNTED ON DUNNAGE. IT IS RECOMMENDED THE DUCTS MUST BE SUPPORTED BY CROSS BRACES AS DONE ON ACCESSORY ROOF CURB.
DIMENSIONS IN \uparrow ARE IN MILLIMETERS.
 - HOOD REMOVED
DAMPER OPENING [10193]
WITH HOOD [11544]
OPENING [11544]
PANEL REMOVED
VIEW A-A
SCALE 13:320
 - NO POWER EXHAUST OR BAROMETRIC RELIEF

- NOTES:
- Weights include economizer.
 - Center of gravity.
 - Unit clearances:

- Top of units: no overhang
 Economizer coils: 4'-0" [1219]
 Economizer sides: 6'-0" [1829]
 Heat side: 4'-0" [1219]
 Filter access side: 10'-0" [3048] (for removal of evaporator coil)
- Bottom ducts are designed to be attached to accessory roof curb. If unit is mounted on ductage, it is recommended that the ducts be supported by cross braces as done on accessory roof curb.
- Dimensions in [] are in millimeters. All other dimensions are in inches.

UNIT SIZE	OPERATING WEIGHT		CENTER OF GRAVITY		CORNER WEIGHT (LB)			
	LB	KG	A F1/IN	B F1/IN	1	2		
50A2/A3/A6/A7/040	5564	2524	10 - 1/4"	3 - 5/8"	1276	1137	1481	1671
50A2/A3/A6/A7/050	5744	2606	11 - 1/2"	3 - 5/8"	1338	1214	1509	1684

UNIT SIZE	OPERATING WEIGHT		CENTER OF GRAVITY		CORNER WEIGHT (KG)			
	KG	MM	A MM	B MM	1	2		
50A2/A3/A6/A7/040	2524	3093	262	102	570	516	672	758
50A2/A3/A6/A7/050	2606	3035	335	103	601	531	684	764

*Operating weight includes largest indoor fan motor, microchannel heat exchanger, modulating power exhaust (variable air volume units), and variable frequency drive (variable air volume units).

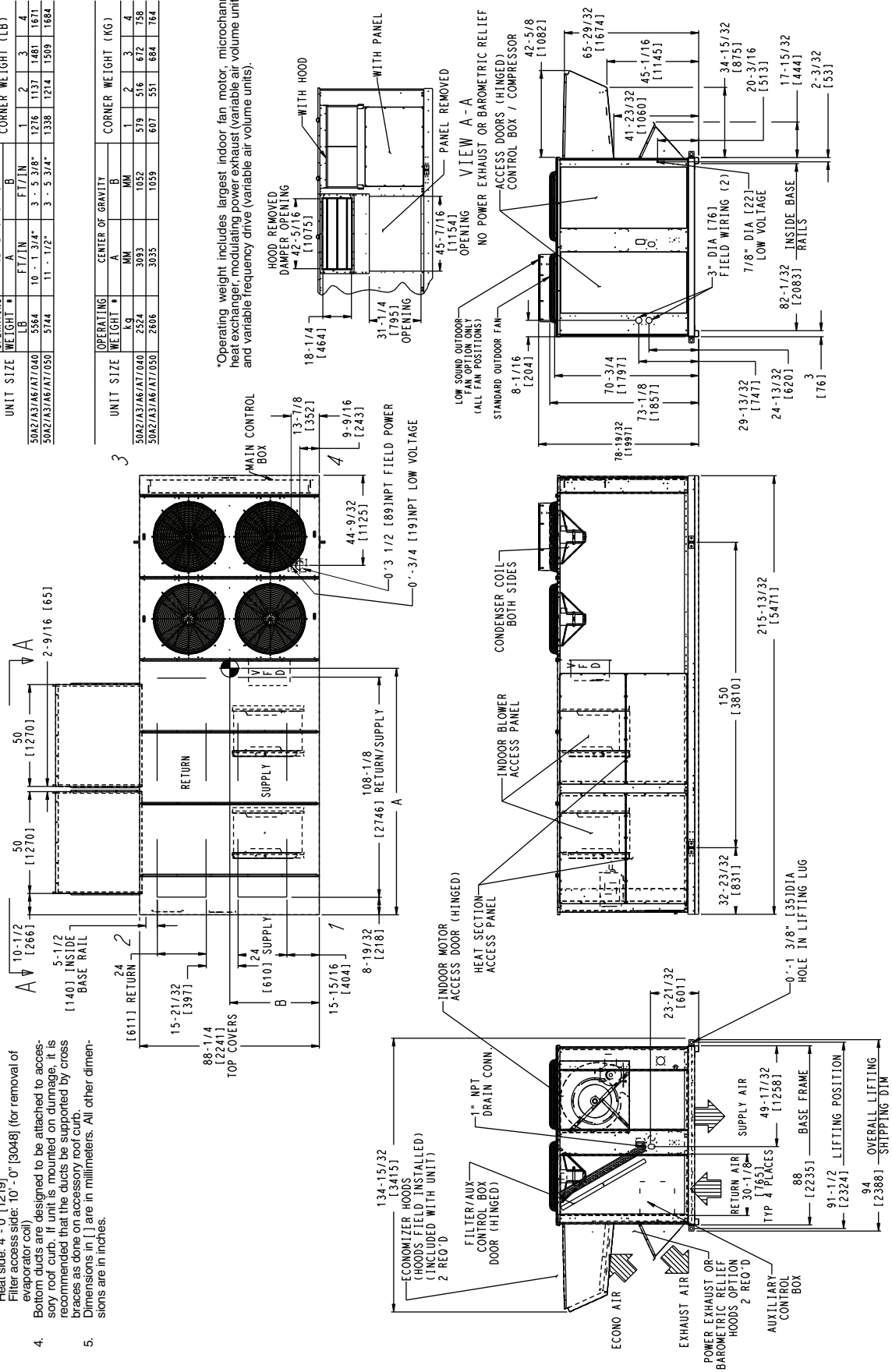
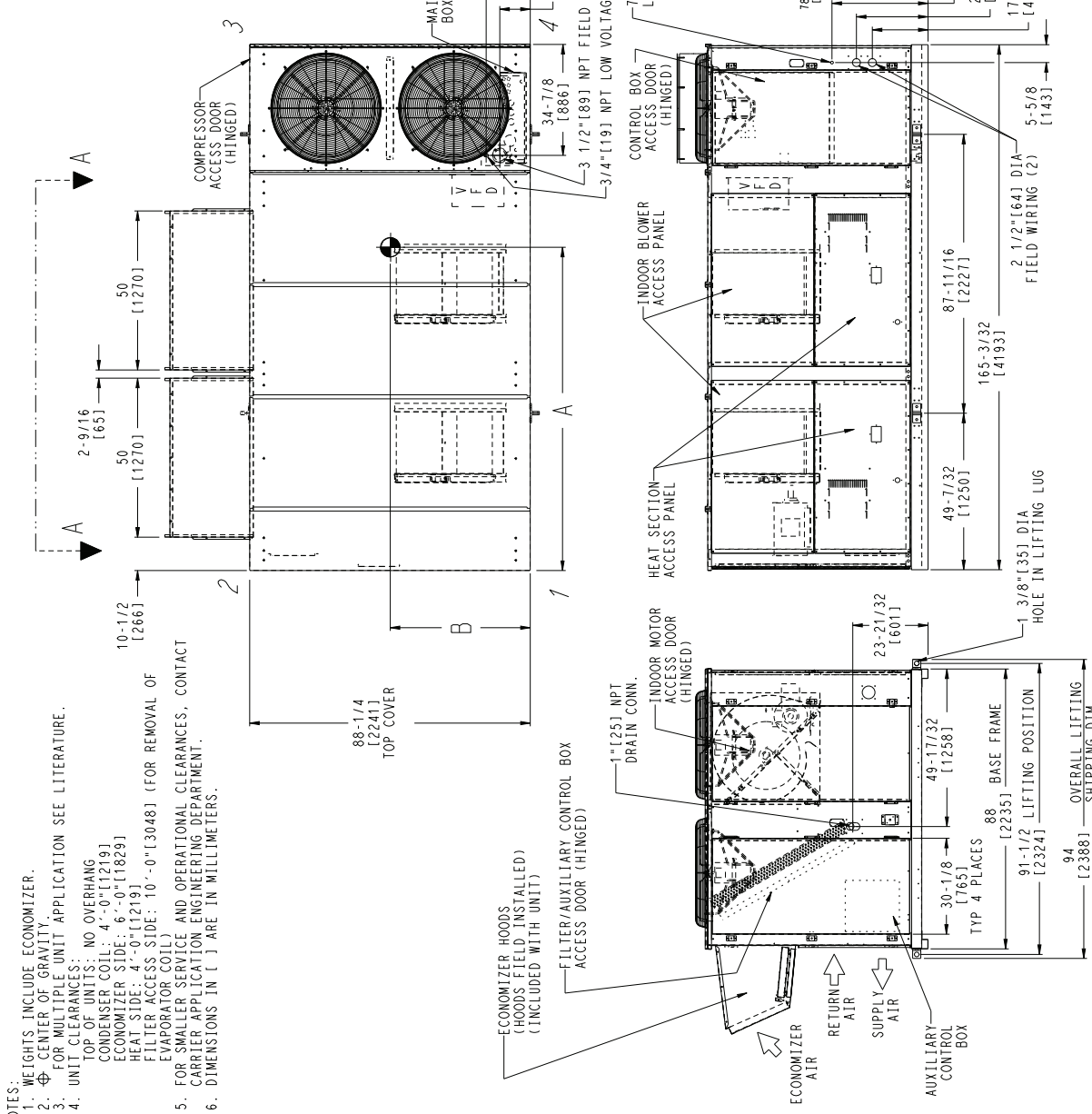

Fig. 7 — Base Unit Dimensions — 50A2,A3,A6,A7040-050

UNIT SIZE	OPERATING WEIGHT *		CENTER OF GRAVITY		CORNER WEIGHT (LBS)		
	LBS	FT./IN.	A	B	1	2	3
50A4/A5/A8/A9/020	4677	7 - 10 1/4"	4 - 1 1/2"	821	1184	1446	1225
50A4/A5/A8/A9/025	4813	7 - 10 7/8"	4 - 1 1/4"	835	1210	1478	1290
50A4/A5/A8/A9/027	4879	7 - 9 5/8"	4 - 0 1/2"	901	1210	1478	1290
50A4/A5/A8/A9/030	4910	7 - 7 5/8"	4 - 0 3/4"	931	1253	1467	1259
50A4/A5/A8/A9/035	5327	7 - 8 5/8"	3 - 9 3/4"	1073	1263	1506	1486

UNIT SIZE	OPERATING WEIGHT *		CENTER OF GRAVITY		CORNER WEIGHT (KGS)		
	kg	MM	A	B	1	2	3
50A4/A5/A8/A9/020	2122	2394	1257	373	537	656	556
50A4/A5/A8/A9/025	2183	2410	1248	379	549	670	585
50A4/A5/A8/A9/027	2213	2377	1232	409	549	670	585
50A4/A5/A8/A9/030	2216	2327	1238	422	568	666	571
50A4/A5/A8/A9/035	2416	2353	1161	487	573	683	674

* OPERATING WEIGHT INCLUDES LARGEST I/FM, MCHX, MODULATING POWER EXHAUST (VAV), AND VFD (VAV).



- WEIGHTS INCLUDE ECONOMIZER.
- CENTER OF GRAVITY.
- FOR MULTIPLE UNIT APPLICATION SEE LITERATURE.
- UNIT CLEARANCES:
TOP OF UNITS: NO OVERHANG
CONDENSER COIL: 4'-0" [1219]
ECONOMIZER SIDE: 6'-0" [1829]
HEAT SIDE: 4'-0" [1219]
FILTER ACCESS SIDE: 10'-0" [3048] (FOR REMOVAL OF EVAPORATOR COIL)
- FOR SMALLER SERVICE AND OPERATIONAL CLEARANCES, CONTACT CARRIER APPLICATION ENGINEERING DEPARTMENT.
- DIMENSIONS IN [] ARE IN MILLIMETERS.

Fig. 8 — Base Unit Dimensions — 50A4,A5,A8,A9/020-035

- NOTES:
 1. Weights include economizer.
 2. Center of gravity.
 3. Unit clearances.
 4. Dimensions in [] are in millimeters. All other dimensions are in inches.

Top of unit: no overhang
 Condenser coil: 4'-0" [1219]
 Economizer side: 6'-0" [1829]
 Heat side: 4'-0" [1219]
 Filter access side: 10'-0" [3048] (for removal of evaporator coil)

Dimensions in [] are in millimeters. All other dimensions are in inches.

UNIT SIZE	OPERATING WEIGHT (LB)		CENTER OF GRAVITY		CORNER WEIGHT (LB)	
	LB	KG	A	B	1	2
50A4/A5/A8/A9/040	5757	2612	FT/IN	FT/IN	1	2
						3
50A4/A5/A8/A9/050	5937	2693	3'-9 3/8"	3'-9 1/2"	1211	1428
			9'-6 1/4"	9'-6 1/2"	1500	1578
					1276	1505
					1586	1591

UNIT SIZE	OPERATING WEIGHT (KG)		CENTER OF GRAVITY		CORNER WEIGHT (KG)	
	KG	MM	MM	MM	1	2
50A4/A5/A8/A9/040	2612	2956	1152	1152	549	648
					699	716
50A4/A5/A8/A9/050	2693	2904	1156	1156	579	683
					710	722

*Operating weight includes largest indoor fan motor, microchannel heat exchanger, modulating power exhaust (variable air volume units), and variable frequency drive (variable air volume units).

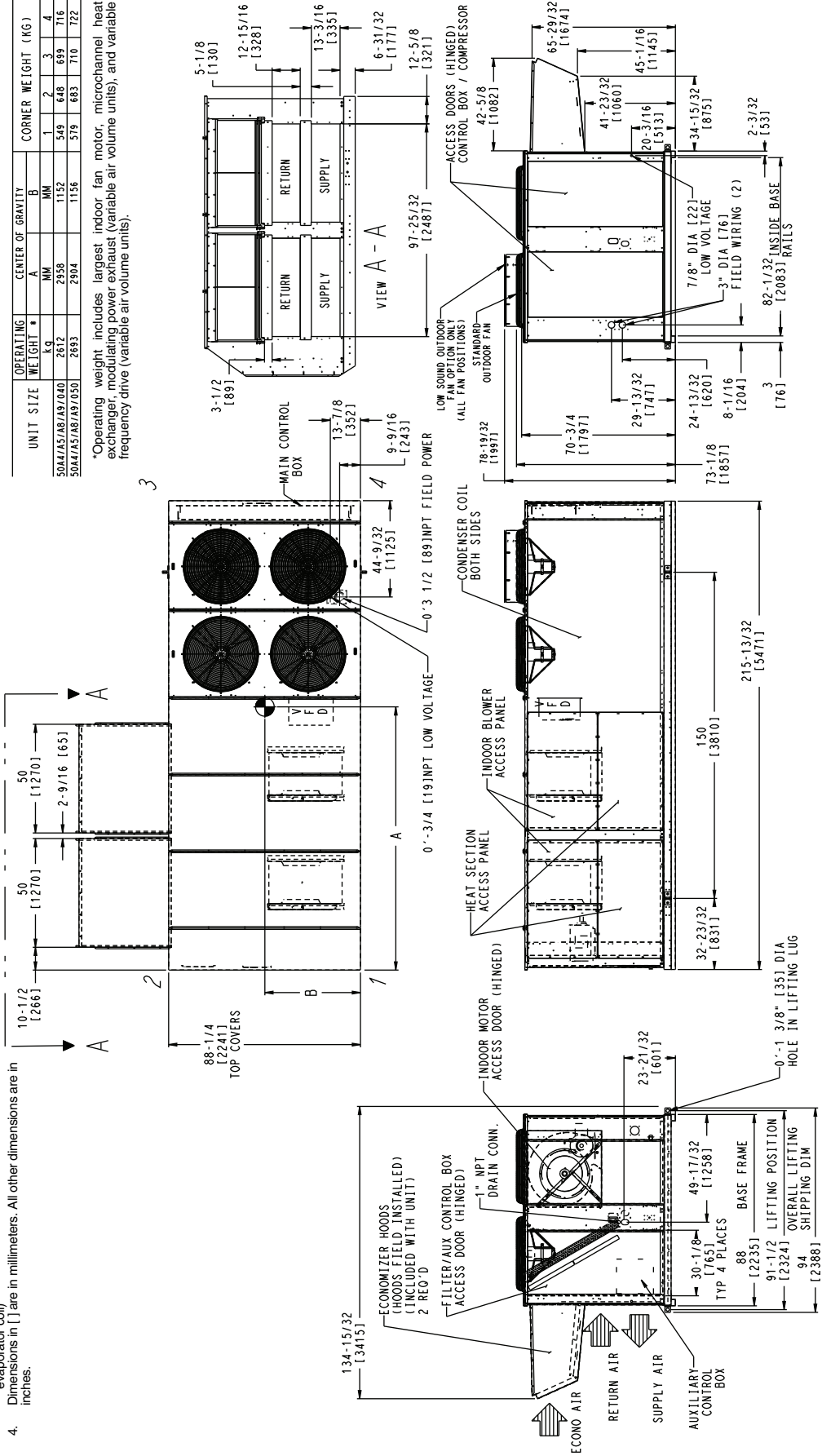

Fig. 9 — Base Unit Dimensions — 50A4,A5,A8,A9040-050

FOR CENTERS OF GRAVITY,
OPERATING AND CORNER
WEIGHTS, SEE FIG. 14

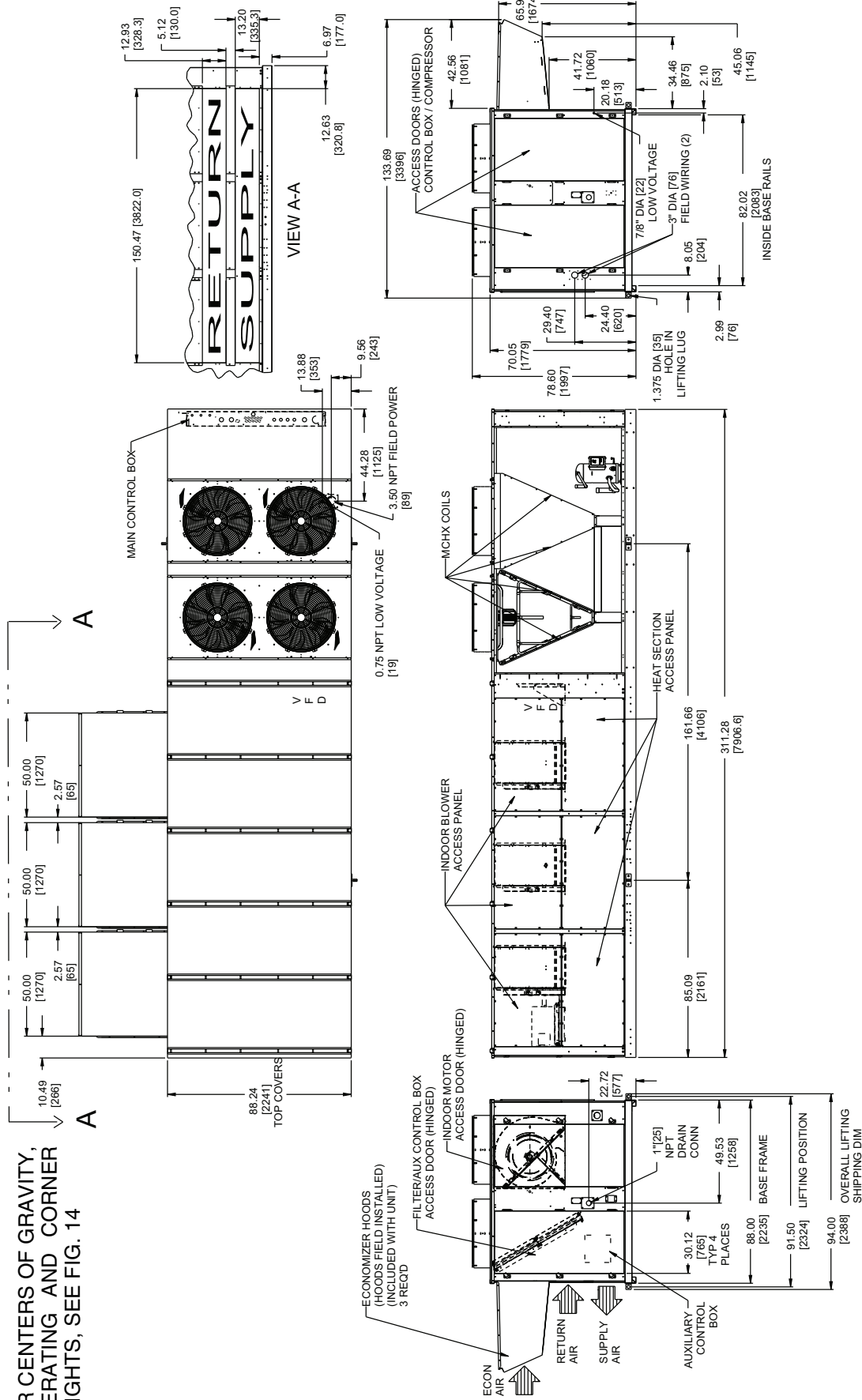

Fig. 11 — Base Unit Dimensions — 50A4,A5,A8,A9060 MCHX

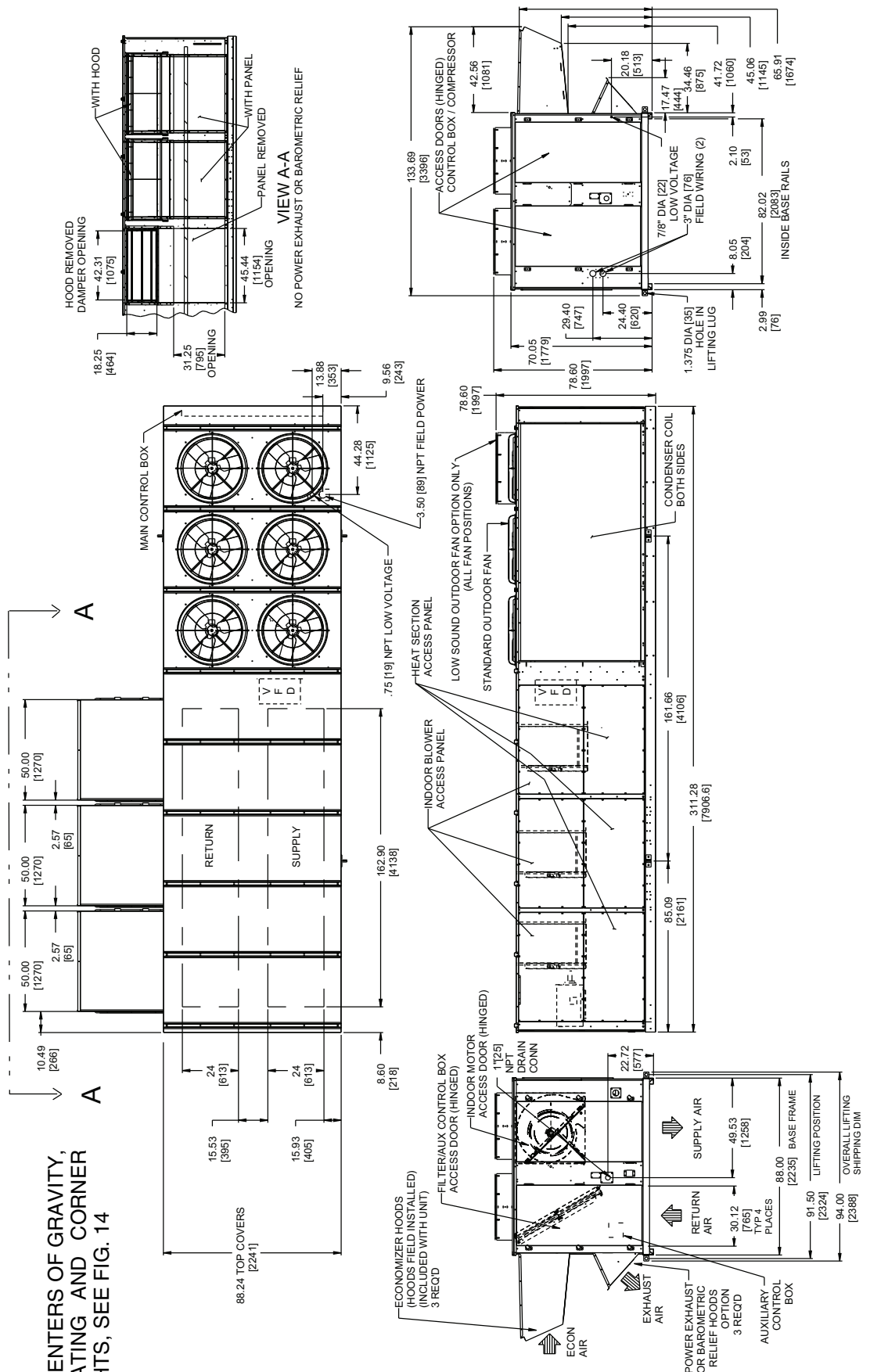

Fig. 12 — Base Unit Dimensions — 50A2,A3,A6,A7060 RTPF

FOR CENTERS OF GRAVITY,
OPERATING AND CORNER
WEIGHTS, SEE FIG. 14

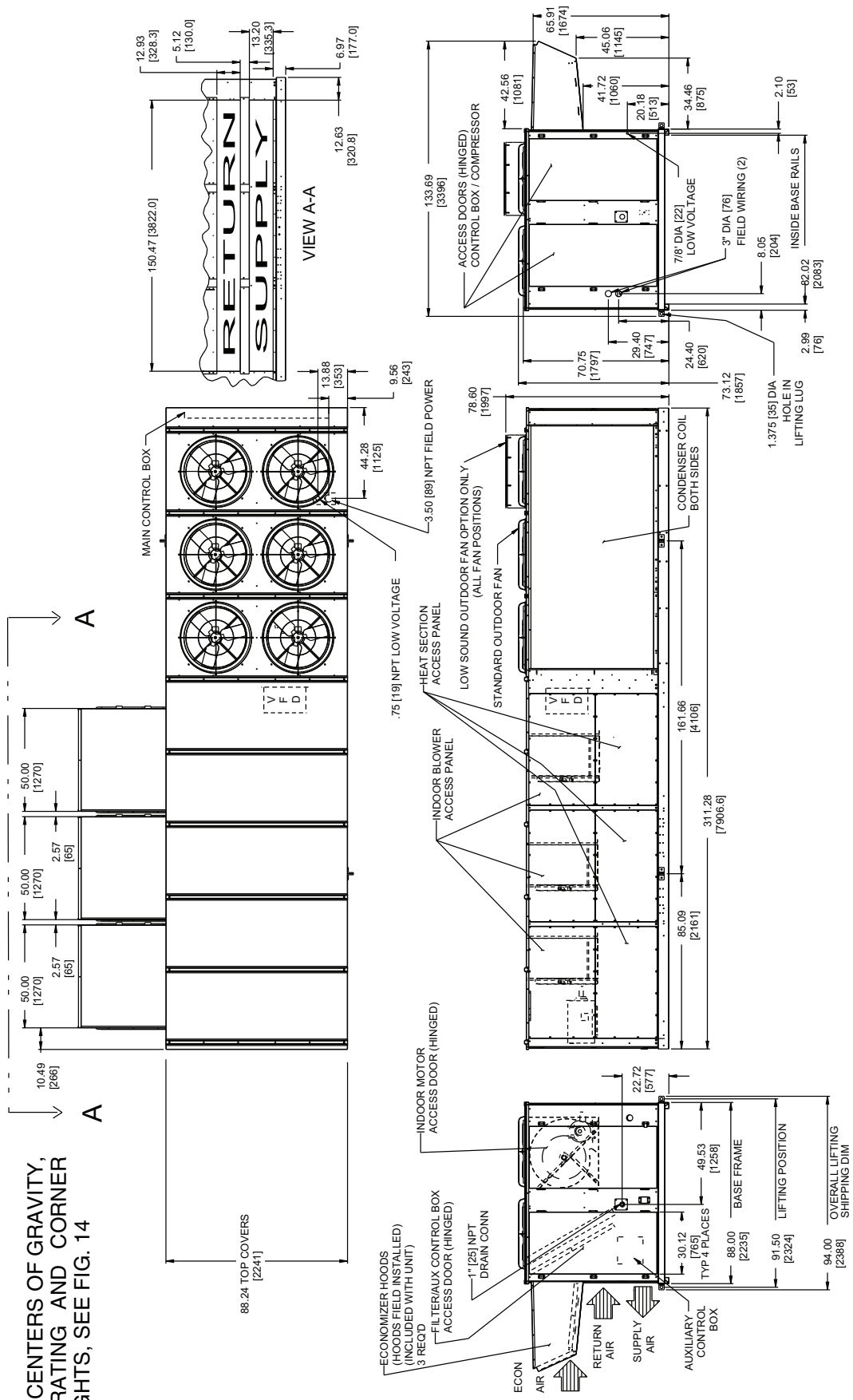

Fig. 13 — Base Unit Dimensions — 50A4,A5,A8,A9060 RTPF

BASE UNIT WEIGHTS (SEE NOTE 5)	
UNIT SIZE	WEIGHT (kg)
50A2/A3/A6/A7	6826 (3096)
50A4/A5/A8/A9	7041 (3194)

OPTIONS / ACCESSORIES (SEE NOTE 5)	
OPTION	WEIGHT (kg)
BAROMETRIC RELIEF	450 (204)
NON MOD. POWER EXHAUST	675 (306)
MOD. POWER EXHAUST	725 (329)
ELECTRIC HEAT	165 (75)
CU TU/AL F IN COND COIL	26 (12)
CU TU/CU F IN COND COIL	677 (307)

- NOTES:**
- Weights include economizer or outdoor air damper.
 - Center of gravity.
 - Unit clearances:
 Top of units: no overhang
 Condenser coil: 4' - 0" [1219]
 Economizer side: 6' - 0" [1829]
 Heat side: 4' - 0" [1219]
 Filter access side: 10' - 0" [3048] (for removal of evaporator coil)
 - Bottom ducts are designed to be attached to accessory roof curb, if unit is mounted on drainage, it is recommended that the ducts be supported by cross braces as done on accessory roof curb.
 - Base unit weights include outdoor air hoods and filters (indoor fan motor is not included). Add indoor fan motor, FIOPs, and accessories for total operating weight.
 - VAV motor weights include indoor motor, VFD, VFD transducer, and associated wiring.
 - Dimensions in [] are in millimeters. All other dimensions are in inches.
 - For side-supply/return applications, a single return and supply ductwork connection is recommended for covering all three return and all three supply openings. The entire area around the duct openings is available for a 1.5" duct flange attachment.

	CV MOTOR WEIGHTS LB (kg)		VAV MOTOR WEIGHTS LB (kg) (SEE NOTE 6)	
	HIGH EFFCY IFM	PREMIUM EFFCY IFM	HIGH EFFCY IFM	PREMIUM EFFCY IFM
25 HP (18.65 kW)	240 (109)	309 (140)	375 (170)	444 (201)
30 HP (22.38 kW)	240 (109)	319 (145)	375 (170)	454 (206)
40 HP (29.84 kW)	283 (128)	355 (161)	418 (190)	490 (222)
	372 (169)	415 (188)	507 (230)	550 (249)
	372 (169)	410 (186)	507 (230)	545 (247)

UNIT SIZE	OPERATING WEIGHT LB	CENTER OF GRAVITY		CORNER WEIGHT (LB)			
		A FT/IN	B FT/IN	1	2	3	4
50A2/A3/A6/A7/060	8311	15 - 5"	3 - 7 3/8"	1710	1663	2433	2504
50A4/A5/A8/A9/060	8526	14 - 8 1/2"	3 - 11 1/8"	1613	2078	2484	2351

UNIT SIZE	OPERATING WEIGHT KG	CENTER OF GRAVITY		CORNER WEIGHT (kg)			
		A MM	B MM	1	2	3	4
50A2/A3/A6/A7/060	3770	4698	1102	776	755	1104	1136
50A4/A5/A8/A9/060	3868	4484	1196	732	942	1127	1066

*Operating weight includes largest indoor fan motor, microchannel heat exchanger, modulating power exhaust (variable air volume units), and variable frequency drive (variable air volume units).

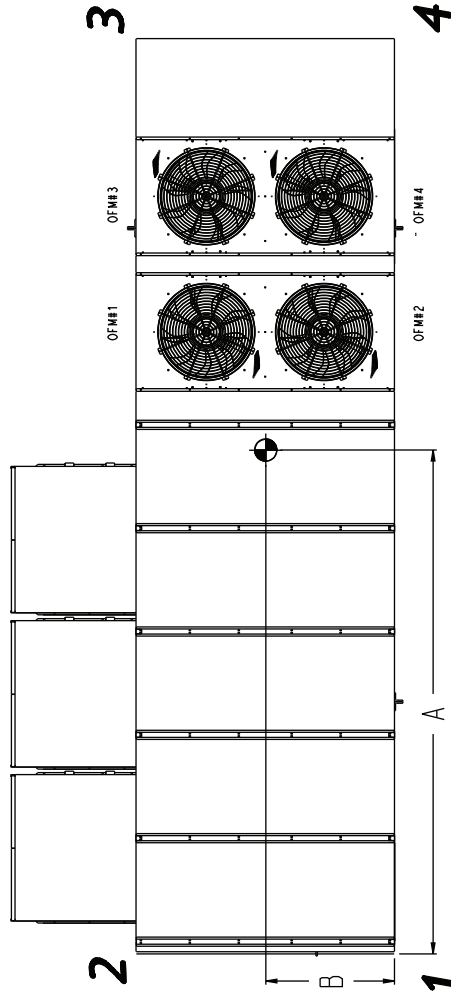

Fig. 14 — Center of Gravity and Weights — 50A060

Table 1 — Physical Data — 50A Units

UNIT 50A	020			025			027			030		
NOMINAL CAPACITY (tons)	20			25			27			30		
BASE UNIT OPERATING WEIGHT (lb)	See Unit Weights Table											
COMPRESSOR Quantity ... Type (Ckt 1/Ckt 2) Number of Refrigerant Circuits Oil	2 ... ZP67/1...ZP91 2 Precharged			2 ... ZP91/1...ZP91 2 Precharged			2 ... ZP91/1...ZP91 2 Precharged			2...ZP72, 2...ZP72 2 Precharged		
REFRIGERANT Operating Charge (lb), Ckt 1/Ckt 2 RTPF Coils MCHX Coils MCHX Coils with Humidi-Mizer® Coil	R-410A											
MCHX CONDENSER* Quantity Total Face Area (sq ft)	1 32.9			1 32.9			1 32.9			1 32.9		
RTPF CONDENSER Quantity Rows...Fins/in. Total Face Area (sq ft)	1 2...15 33.3			1 3...15 33.3			1 3...15 33.3			1 4...15 33.3		
CONDENSER FAN Nominal Cfm Quantity... Diameter (in.) Motor Hp	Propeller Type											
	19,500 2 ... 30 1			19,500 2 ... 30 1			19,500 2 ... 30 1			19,500 2 ... 30 1		
EVAPORATOR COIL Tube Size (in.) Rows ... Fins/in. Total Face Area (sq ft)	Cross-Hatched Copper Tubes, Aluminum Plate Fins with Intertwined Circuits											
	³ / ₈ 3 ... 15 31.7			³ / ₈ 4 ... 14 31.7			³ / ₈ 4 ... 15 31.7			³ / ₈ 4 ... 15 31.7		
HUMIDI-MIZER COIL Quantity Face Area (sq ft)	1 14.4			1 14.4			1 14.4			1 14.4		
EVAPORATOR FAN Quantity ... Size (in.) Type Drive Nominal Cfm Motor Hp Motor Frame Size Motor Bearing Type Maximum Allowable Rpm Motor Pulley Pitch Diameter (in.) Nominal Motor Shaft Diameter (in.) Fan Pulley Pitch Diameter (in.) Nominal Fan Shaft Diameter (in.) Belt Quantity Belt Type Belt Length (in.) Pulley Center Line Distance (in.) Factory Speed Setting (rpm)	Centrifugal Type											
	2 ... 20 X 15 Belt 8,000 5 10 15 184T 215T 254T			2 ... 20 X 15 Belt 10,000 5 10 15 184T 215T 254T			2 ... 20 X 15 Belt 11,000 10 15 20 215T 254T 256T			2 ... 20 X 15 Belt 12,000 10 15 20 215T 254T 256T		
	Ball 1200 4.8 4.4 5.7 1 ¹ / ₈ 1 ³ / ₈ 1 ⁵ / ₈ 12.4 8.6 9.1			Ball 1200 5.2 6.1 5.5 1 ¹ / ₈ 1 ³ / ₈ 1 ⁵ / ₈ 12.4 11.1 8.7			Ball 1200 4.4 4.9 5.9 1 ³ / ₈ 1 ⁵ / ₈ 1 ⁵ / ₈ 9.4 8.1 8.7			Ball 1200 4.4 5.7 5.9 1 ³ / ₈ 1 ⁵ / ₈ 1 ⁵ / ₈ 9.0 9.1 8.7		
	1 ¹⁵ / ₁₆ 1 BX56 BX50 5VX530 56 63 53			1 ¹⁵ / ₁₆ 1 BX56 5VX570 5VX530 56 57 53			1 ¹⁵ / ₁₆ 2 BX50 5VX500 5VX530 50 50 53			1 ¹⁵ / ₁₆ 2 BX50 5VX530 5VX530 50 53 53		
	16.0- 18.7			15.6- 18.4			15.0- 17.9			15.6- 18.4		
	717 924 1096			773 962 1106			848 1059 1187			856 1096 1187		
HIGH-PRESSURE SWITCH (psig) Cutout Reset (Auto.)	650 500			650 500			650 500			650 500		
MIXED-AIR FILTERS Quantity ... Size (in.) Standard Pleated	10 ... 20 x 24 x 2 5 ... 20 x 20 x 4 5 ... 20 x 24 x 4			10 ... 20 x 24 x 2 5 ... 20 x 20 x 4 5 ... 20 x 24 x 4			10 ... 20 x 24 x 2 5 ... 20 x 20 x 4 5 ... 20 x 24 x 4			10 ... 20 x 24 x 2 5 ... 20 x 20 x 4 5 ... 20 x 24 x 4		
OUTDOOR-AIR FILTERS Quantity...Size (in.)	8...16 x 25 x 2 4...20 x 25 x 2											
POWER EXHAUST Motor, Quantity...Hp Fan, Diameter...Width (in.)	Direct Drive, Single-Phase Motors (Factory-Wired for High Speed Operation), Forward-Curved Fan Wheels with Backdraft Dampers on Each Fan Housing 4...1 11 x 10											

LEGEND

MCHX — Microchannel Heat Exchanger
RTPF — Round Tube Plate Fin

*Sizes 020 to 027: Circuit 1 uses the lower portion of condenser coil, Circuit 2 uses the upper portion.
Sizes 030 and 035: Circuit 1 uses the upper portion of condenser coil, Circuit 2 uses the lower portion.
Sizes 040 and 050: Circuit 1 uses the left condenser coil, Circuit 2 the right.
Size 060: Circuit A uses the two MCHX coils near the bulkhead, Circuit B uses the two MCHX coils near the control box.

Table 1 — Physical Data — 50A Units (cont)

UNIT 50A	035			040			050			060		
NOMINAL CAPACITY (tons)	35			40			50			60		
BASE UNIT OPERATING WEIGHT (lb)	See Unit Weights Table											
COMPRESSOR	2 ... ZP67/2...ZP104			2...ZP104/2...ZP104			2...ZP122/2...ZP122			2...ZP154/2...ZP154		
Quantity ... Type (Ckt 1/Ckt 2)	2			2			2			2		
Number of Refrigerant Circuits	Precharged			Precharged			Precharged			Precharged		
Oil												
REFRIGERANT	R-410A											
Operating Charge (lb), Ckt 1/Ckt 2	28.7/44.0			44.0/44.0			56.3/57.3			78.5/82.0		
RTPF Coils	17.9/26.0			23.0/23.5			27.0/28.0			36.6/37.8		
MCHX Coils	17.9/31.5			23.0/30.5			26.5/34.5			36.6/47.6		
MCHX Coils with Humidi-MiZer® Coil												
MCHX CONDENSER*	1			2			2			4		
Quantity	32.9			65.8			65.8			105.2		
Total Face Area (sq ft)												
RTPF CONDENSER	1			2			2			2		
Quantity	4...15			3...15			4...15			6...30		
Rows...Fins/in	33.3			66.7			66.7			100.0		
Total Face Area (sq ft)												
CONDENSER FAN	Propeller Type											
Nominal Cfm	19,500			32,000			35,000			40,000		
Quantity... Diameter (in.)	2 ... 30			4 ... 30			4 ... 30			4...30.5(MCHX), 6...30(RTPF)		
Motor Hp	1			1			1			1		
EVAPORATOR COIL	Cross-Hatched Copper Tubes, Aluminum Plate Fins with Intertwined Circuits											
Tube Size (in.)	1/2			1/2			1/2			1/2		
Rows ... Fins/in.	6 ... 16			4 ... 17			6 ... 16			4...17		
Total Face Area (sq ft)	31.3			31.3			31.3			48.1		
HUMIDI-MIZER COIL	1			1			1			1		
Quantity	14.4			14.4			14.4			14.4		
Face Area (sq ft)												
EVAPORATOR FAN	Centrifugal Type											
Quantity ... Size (in.)	2 ... 20 X 15			2 ... 20 X 15			2 ... 20 X 15			3 ... 20 X 15		
Type Drive	Belt			Belt			Belt			Belt		
Nominal Cfm	14,000			16,000			18,000			24,000		
Motor Hp	15	20	25	15	20	25	20	25	30	25	30	40
Motor Frame Size	254T	256T	284T	254T	256T	284T	256T	284T	286T	284T	286T	324T
Motor Bearing Type	Ball			Ball			Ball			Ball		
Maximum Allowable Rpm	1300			1300			1300			1200		
Motor Pulley Pitch Diameter (in.)	5.1	5.7	6.2	5.3	5.7	7.5	5.7	6.2	6.7	5.3	5.9	6.5
Nominal Motor Shaft Diameter (in.)	1 ⁵ / ₈	1 ⁵ / ₈	1 ⁷ / ₈	1 ⁵ / ₈	1 ⁵ / ₈	1 ⁷ / ₈	1 ⁵ / ₈	1 ⁷ / ₈	1 ⁷ / ₈	1 ⁷ / ₈	1 ⁷ / ₈	2 ¹ / ₈
Fan Pulley Pitch Diameter (in.)	8.7	8.7	8.7	9.5	9.5	11.1	9.5	9.5	9.5	9.1	9.5	9.5
Nominal Fan Shaft Diameter (in.)	1 ¹⁵ / ₁₆			1 ¹⁵ / ₁₆			1 ¹⁵ / ₁₆			1 ¹⁵ / ₁₆		
Belt Quantity	2	2	2	2	2	2	2	2	2	3	3	3
Belt Type	5VX500	5VX530	5VX550	5VX530	5VX550	5VX590	5VX550	5VX570	5VX570	5VX530	5VX550	5VX570
Belt Length (in.)	50	53	55	53	55	59	55	57	57	53	55	57
Pulley Center Line Distance (in.)	15.0-	15.0-	15.0-	15.0-	15.0-	14.6-	15.0-	14.6-	14.6-	15.2-	14.7-	14.2-
Factory Speed Setting (rpm)	17.9	17.9	17.9	17.9	17.9	17.6	17.9	17.6	17.6	17.5	17.2	17.0
	1025	1147	1247	976	1050	1182	1050	1142	1234	1019	1087	1197
HIGH-PRESSURE SWITCH (psig)	650			650			650			650		
Cutout	500			500			500			500		
Reset (Auto.)												
MIXED-AIR FILTERS	10 ... 20 x 24 x 2			10 ... 20 x 24 x 2			10 ... 20 x 24 x 2			16...20 x 24 x 2		
Quantity ... Size (in.) Standard	5 ... 20 x 20 x 4			5 ... 20 x 20 x 4			5 ... 20 x 20 x 4			8...20 x 20 x 4		
Pleated	5 ... 20 x 24 x 4			5 ... 20 x 24 x 4			5 ... 20 x 24 x 4			8...20 x 24 x 4		
OUTDOOR-AIR FILTERS	8...16 x 25 x 2			8...16 x 25 x 2			8...16 x 25 x 2			12...16 x 25 x 2		
Quantity...Size (in.)	4...20 x 25 x 2			4...20 x 25 x 2			4...20 x 25 x 2			6...20 x 25 x 2		
POWER EXHAUST	Direct Drive, Single-Phase Motors (Factory-Wired for High Speed Operation), Forward-Curved Fan Wheels with Backdraft Dampers on Each Fan Housing											
Motor, Quantity...Hp	4...1			4...1			4...1			6...1		
Fan, Diameter...Width (in.)	11 x 10			11 x 10			11 x 10			11 x 10		

LEGEND

MCHX — Microchannel Heat Exchanger
RTPF — Round Tube Plate Fin

*Sizes 020 to 027: Circuit 1 uses the lower portion of condenser coil, Circuit 2 uses the upper portion.
 Sizes 030 and 035: Circuit 1 uses the upper portion of condenser coil, Circuit 2 uses the lower portion.
 Sizes 040 and 050: Circuit 1 uses the left condenser coil, Circuit 2 the right.
 Size 060: Circuit A uses the two MCHX coils near the bulkhead, Circuit B uses the two MCHX coils near the control box.

Table 2 — 50A Base Unit Operating Weights (lb)

UNIT SIZE	020	025	027	030	035	040	050	060
50A2,A3,A6,A7	3625	3761	3761	3792	4025	4455	4599	6826
50A4,A5,A8,A9	3703	3839	3839	3870	4218	4648	4792	7041

Table 3 — 50A Option and Accessory Weights (lb)

UNIT SIZE	020	025	027	030	035	040	050	060
Barometric Relief	300	300	300	300	300	300	300	450
Non-Modulating Power Exhaust	450	450	450	450	450	450	450	675
Modulating Power Exhaust	500	500	500	500	500	500	500	725
Electric Heat	110	110	110	110	110	110	110	165
Cu Tube/Alum Fin Cond. Coil	100	100	100	150	150	187	317	26
Cu Tube/Cu Fin Cond. Coil	263	263	263	370	370	512	751	677
OA Hood Crate/Packaging (Less Hoods' Weight)	45	45	45	45	45	45	45	45
	(Packaging Only)							
Outdoor Air Hoods/Filters (included with unit)	170	170	170	170	170	170	170	255
Hail Guards	73	73	73	73	73	146	146	219
Roof Curb (14-in.)	365	365	365	365	365	410	410	540
Double Wall	275	275	275	275	275	275	275	375
Humidi-MiZer Coil	150	150	150	150	150	180	180	195

Table 4 — Constant Volume Fan Motor Weights (lb)

MOTOR HP	UNIT VOLTAGE	PREMIUM EFFICIENCY IFM
5 HP	230/460	80
	380	75
	575	80
10 HP	230/460	126
	380	120
	575	126
15 HP	230/460	217
	380	155
	575	217
20 HP	230/460	250
	380	185
	575	250
25 HP	230/460	309
	380	225
	575	309
30 HP	230/460	303
	380	283
	575	303
40 HP	230/460	551
	380	601
	575	551

Table 5 — Variable Air Volume / Staged Air Volume Fan Motor Weights (lb)

MOTOR HP	UNIT VOLTAGE	PREMIUM EFFICIENCY IFM
5 HP	230/460	138
	380	133
	575	149
10 HP	230/460	195
	380	198
	575	195
15 HP	230/460	316
	380	254
	575	319
20 HP	230/460	385
	380	320
	575	357
25 HP	230/460	444
	380	360
	575	454
30 HP	230/460	338
	380	318
	575	342
40 HP	230/460	686
	380	736
	575	686

LEGEND AND NOTES FOR TABLES 2-5

- LEGEND
- Cu — Copper
 - FIOP — Factory-Installed Option
 - HP — Horsepower
 - IFM — Indoor Fan Motor
 - OA — Outdoor Air
 - SAV — Staged Air Volume
 - VAV — Variable Air Volume
 - VFD — Variable Frequency Drive

- NOTES:
1. Base unit weight includes outdoor-air hoods. Base unit weight does NOT include indoor-fan motor. ADD indoor-fan motor, FIOPs, and accessories for TOTAL operating weight.
 2. VAV/SAV™ motor weights include the indoor motor and the VFD, optional VFD bypass, VFD transducer and associated wiring.

CAUTION - NOTICE TO RIGGERS: ALL PANELS MUST BE IN PLACE WHEN RIGGING.

NOTE: Rig with four cables and spread with two 92 inch (2337 MM) spreader bars. Maintain a distance of 74 inches (1880 MM) from top of unit to eyehook.

MODEL	WEIGHT		A		B		C	
	LBS	KGS	INCHES	MM	INCHES	MM	INCHES	MM
50A2/A3/A6/A7 027	4854	2202	87.7	2227	97.2	2469	44.1	1120
48A2/A3/A6/A7D 027	4944	2243	87.7	2227	96.1	2441	43.7	1110
48A2/A3/A6/A7E 027	5024	2279	87.7	2227	95.6	2428	43.4	1102
50A4/A5/A8/A9 027	4932	2237	87.7	2227	93.6	2379	48.4	1230
48A4/A5/A8/A9D 027	4984	2261	87.7	2227	92.7	2354	48.0	1220
48A4/A5/A8/A9E 027	5064	2297	87.7	2227	92.3	2344	47.7	1211
50A2/A3/A6/A7 030	4834	2193	87.7	2227	95.2	2417	44.4	1128
48A2/A3/A6/A7D 030	4924	2233	87.7	2227	94.0	2389	44.0	1118
48A2/A3/A6/A7E 030	5004	2270	87.7	2227	93.6	2376	43.7	1110
50A4/A5/A8/A9 030	4912	2228	87.7	2227	91.6	2327	48.8	1238
48A4/A5/A8/A9D 030	4964	2252	87.7	2227	90.6	2302	48.3	1228
48A4/A5/A8/A9E 030	5044	2288	87.7	2227	90.3	2293	48.0	1219
50A2/A3/A6/A7 035	5121	2323	87.7	2227	95.9	2436	41.4	1053
48A2/A3/A6/A7D 035	5326	2416	87.7	2227	94.8	2408	41.0	1042
48A2/A3/A6/A7E 035	5486	2489	87.7	2227	94.2	2394	40.7	1035
50A4/A5/A8/A9 035	5314	2411	87.7	2227	92.7	2354	45.7	1162
48A4/A5/A8/A9D 035	5366	2434	87.7	2227	91.7	2329	45.3	1151
48A4/A5/A8/A9E 035	5526	2507	87.7	2227	91.3	2318	44.9	1141
50A2/A3/A6/A7 040	5559	2521	87.7	2227	121.8	3094	41	1052
48A2/A3/A6/A7D 040	5764	2614	87.7	2227	120.3	3056	41	1041
48A2/A3/A6/A7E 040	5924	2687	87.7	2227	118.8	3018	41	1033
50A4/A5/A8/A9 040	5752	2609	87.7	2227	116.5	2958	45.4	1152
48A4/A5/A8/A9D 040	5804	2633	87.7	2227	115.1	2924	44.9	1142
48A4/A5/A8/A9E 040	5964	2705	87.7	2227	113.9	2893	44.6	1132
50A2/A3/A6/A7 050	5744	2606	87.7	2227	119.5	3035	42	1059
48A2/A3/A6/A7D 050	5949	2699	87.7	2227	118.1	2999	41	1048
48A2/A3/A6/A7E 050	6109	2771	87.7	2227	116.6	2962	41	1040
50A4/A5/A8/A9 050	5937	2693	87.7	2227	114.3	2904	45.5	1156
48A4/A5/A8/A9D 050	5989	2717	87.7	2227	112.9	2868	45.1	1145
48A4/A5/A8/A9E 050	6149	2789	87.7	2227	111.7	2837	44.7	1135
50A2/A3/A6/A7 060	8311	3770	161.7	4106	184.9	4698	43	1102
48A2/A3/A6/A7D 060	8386	3804	161.7	4106	177.6	4511	41	1049
48A2/A3/A6/A7E 060	8626	3913	161.7	4106	170.4	4329	39	996
50A4/A5/A8/A9 060	8526	3868	161.7	4106	176.5	4484	47.1	1196
48A4/A5/A8/A9D 060	8426	3822	161.7	4106	169.6	4309	45.2	1149
48A4/A5/A8/A9E 060	8676	3936	161.7	4106	163.3	4147	43.2	1097

The weight distribution and center of gravity information are representative of a standard unit and include the impact of factory installed economizer, largest I/FW motor & VFD, modulating power exhaust (both factory installed and field installed options), and electric heat (on 50A only). 50EJ500305 REV 2.0

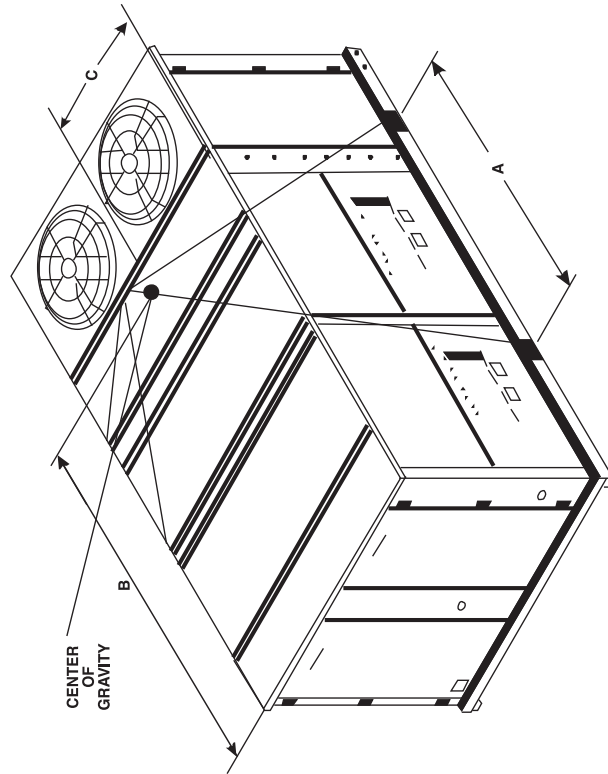

NOTE:
Add 312 lbs (142 kg) for export crating. (027-035 units)
Add 346 lbs (157 kg) for export crating. (040-050 units)
Add 588 lbs (266 kg) for export crating. (060 units)
Add the weights shown below for round tube plate fin coils

Unit Size	027	030-035	040	050	060
Copper Tube/Aluminum Fin Cond Coil	105 lbs (48 kg)	160 lbs (72 kg)	192 lbs (87 kg)	317 lbs (144 kg)	26 lbs (12 kg)
Copper Tube/Copper Fin Cond.Coil	268 lbs (122 kg)	377 lbs (171 kg)	518 lbs (235 kg)	751 lbs (341 kg)	677 lbs (307 kg)

Fig. 15 — Rigging Information

Table 6 — Evaporator Fan Motor Data

UNIT SIZE 50A	MOTOR HP	MOTOR SHAFT DIA. (in.)	FAN SHAFT SPEED (RPM)	MOTOR SHEAVE (P/N)	MOTOR SHEAVE PITCH DIAMETER (in.)	BUSHING DIAMETER (in.)	FAN SHEAVE (P/N)	FAN SHEAVE PITCH DIAMETER (in.)	BUSHING DIAMETER (in.)	BELT (QUANTITY) (P/N)	BELT TENSION (lb at .25 in.)
020	5	1.125	717	BK55	4.8	NONE - 1.125	1B5V124	12.4	B - 1.9375	BX56	8
	10	1.375	924	2BK50	4.4	NONE - 1.375	2B5V86	8.6	B - 1.9375	(2) BX50	8
	15	1.625	1096	2B5V56	5.7	B - 1.625	2B5V90	9.1	B - 1.9375	(2) 5VX530	9
025	5	1.125	773	BK55	5.2	NONE - 1.125	1B5V124	12.4	B - 1.9375	BX56	8
	10	1.375	962	1B5V60	6.1	H - 1.375	1B5V110	11.1	B - 1.9375	5VX570	11
	15	1.625	1106	2B5V54	5.5	B - 1.625	2B5V86	8.7	B - 1.9375	(2) 5VX530	9
027	10	1.375	848	2BK50	4.4	NONE - 1.375	2B5V94	9.4	B - 1.9375	(2) BX50	8
	15	1.625	1059	2B5V56	4.9	B - 1.625	2B5V90	8.1	B - 1.9375	(2) 5VX530	10
	20	1.625	1187	2B5V58	5.9	B - 1.625	2B5V86	8.7	B - 1.9375	(2) 5VX530	11
030	10	1.375	856	2BK50	4.4	H - 1.375	2B5V94	9.0	B - 1.9375	(2) BX50	8
	15	1.625	1096	2B5V56	5.7	B - 1.625	2B5V90	9.1	B - 1.9375	(2) 5VX530	9
	20	1.625	1187	2B5V58	5.9	B - 1.625	2B5V86	8.7	B - 1.9375	(2) 5VX530	11
035	15	1.625	1025	2B5V50	5.1	B - 1.625	2B5V86	8.7	B - 1.9375	(2) 5VX500	9
	20	1.625	1147	2B5V56	5.7	B - 1.625	2B5V86	8.7	B - 1.9375	(2) 5VX530	10
	25	1.875	1247	2B5V62	6.2	B - 1.875	2B5V86	8.7	B - 1.9375	(2) 5VX530	11
040	15	1.625	976	2B5V52	5.3	B - 1.625	2B5V94	9.5	B - 1.9375	(2) 5VX530	10
	20	1.625	1050	2B5V56	5.7	B - 1.625	2B5V94	9.5	B - 1.9375	(2) 5VX550	11
	25	1.875	1182	2B5V74	7.5	B - 1.875	2B5V110	11.1	B - 1.9375	(2) 5VX590	11
050	20	1.625	1050	2B5V56	5.7	B - 1.625	2B5V94	9.5	B - 1.9375	(2) 5VX550	10
	25	1.875	1142	2B5V62	6.2	B - 1.875	2B5V94	9.5	B - 1.9375	(2) 5VX570	11
	30	1.875	1234	2B5V66	6.7	B - 1.875	2B5V94	9.5	B - 1.9375	(2) 5VX570	13
060	25	1.875	1019	3B5V52	5.3	B - 1.875	3B5V90	9.1	B - 1.9375	(3) 5VX530	12
	30	1.875	1087	3B5V58	5.9	B - 1.875	3B5V94	9.5	B - 1.9375	(3) 5VX550	12
	40	2.125	1197	3B5V64	6.5	B - 2.125	3B5V94	9.5	B - 1.9375	(3) 5VX570	14

NOTES:

1. Motor shaft speed is 1750 rpm. The fan shaft diameter is 1¹⁵/₁₆ inches.
2. All indoor fan motors meet the minimum efficiency requirements as established by the Energy Policy Act of 1992 (EPACT), effective October 24, 1997.

1. OAT - ROUTE WIRES LABELED OAT ON IT#175, HARNESS ASY. BEHIND IT#8, UPRIGHT, AND UP THRU IT#1
2. OARH - ROUTE WIRES LABELED OARH ON IT#12, HARNESS ASY. BEHIND IT#8, UPRIGHT, AND UP THRU IT#
- RAT - REMOVE TEMPORARY WIRE TIES ON HARNESS ASY, IT#175, AND CONNECT TO SENSOR.
- RAT & RARH - LOOP EXCESS WIRES FROM RAT & RARH TOGETHER & WIRE TIE WITH IT#760.

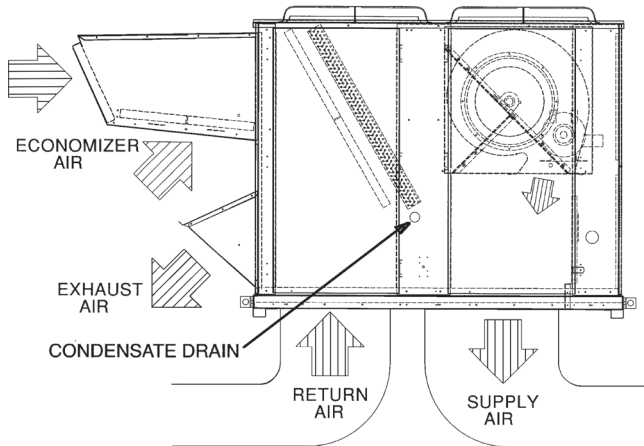

Fig. 16 — Air Distribution — Thru-the-Bottom

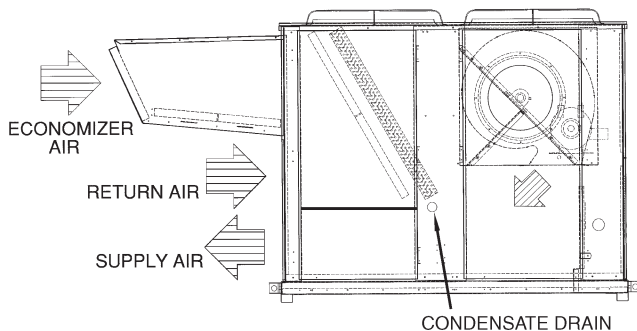

Fig. 17 — Air Distribution — Thru-the-Side

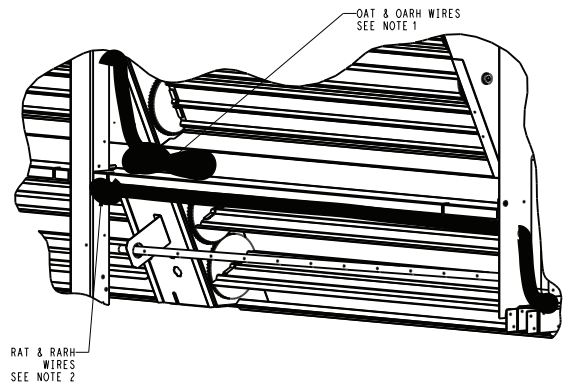

Fig. 18 — Outdoor Air and Return Air Sensors Location

Step 5 — Trap Condensate Drain — See Fig. 6-14 for drain location. Condensate drain is open to atmosphere and must be trapped. Install a trapped drain at the drain location. One 1-in. female pipe coupling is provided inside the unit evaporator section for condensate drain connection. A trap at least 4 in. deep must be used. See Fig. 19. Trap must be installed to prevent freeze-up.

Condensate pans are sloped so that water will completely drain from the condensate pan to comply with indoor air quality guidelines. The condensate drain pans are not insulated.

Step 6 — Make Electrical Connections

POWER WIRING — Units are factory wired for the voltage shown on the unit nameplate.

Provide a unit safety disconnect switch in the main power supply to each unit (see Fig. 20). Select switch size and mounting location in accordance with applicable local codes or National Electrical Code (NEC). If combining the functions of safety disconnect with maximum overcurrent protection (MOCP) fuses (“fused disconnect”), coordinate safety switch size with MOCP size data as marked on unit informative plate.

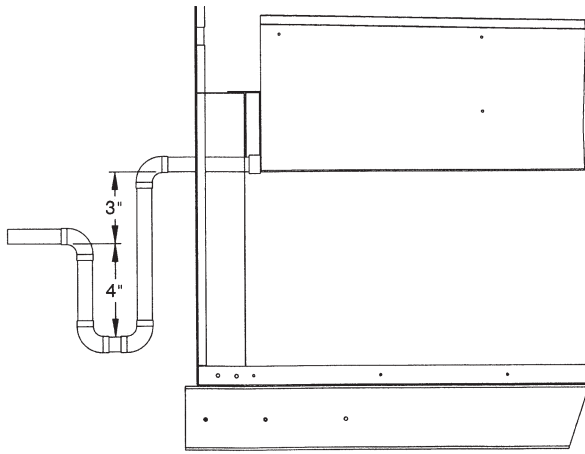

Fig. 19 — Condensate Drain Trap Piping Details (Typical Roof Curb or Slab Mount Shown)

Unit may be equipped with optional factory-installed non-fused disconnect switch (see Fig. 20). Provide maximum over-current protection devices (fuses or UL489 rated breakers, per local codes) in branch circuit wiring remote from unit. Observe requirements of NEC Article 440. Install service switch upstream of remote fuses if required.

The main power terminal block is suitable for use with aluminum or copper wire. See Fig. 20. Units have circuit breakers for compressors, fan motors, and control circuit. If required by local codes, provide an additional disconnect switch. Unit must be electrically grounded in accordance with local codes or, in absence of local codes, with NEC, ANSI (American National Standards Institute) C1-latest year.

FIELD POWER SUPPLY — Unit is factory wired for voltage shown on unit nameplate.

Field wiring can be brought into the unit from bottom (through basepan and roof curb) or through side of unit (corner post next to control box).

A 3¹/₂-in. NPT coupling for field power wiring and a 3/4-in. NPT coupling for 24-v control wiring are provided in basepan. In the side post, there are two 2¹/₂-in. (sizes 020-035) or 3-in. (sizes 040-060) knockouts for the field power wiring. See Fig. 6-13. If control wiring is to be brought in through side of unit, a 7/8-in. diameter hole is provided in the condenser side post next to the control box.

Do not route control wiring in the same conduit as power wiring.

If disconnect box is mounted to corner post, be careful not to drill or screw into the condenser coil.

Routing Through Bottom of Unit — If wiring is brought in through bottom of unit, use field-supplied watertight conduit to route power wiring through the 3¹/₂-in. diameter hole provided in the unit basepan.

Install conduit connector in unit basepan as shown in Fig. 6-13. Route power and ground lines through connector to terminal connections in unit control box as shown on unit wiring diagram and Fig. 20.

Use strain relief going into control box through 3⁵/₈-in. diameter hole provided. After wires are in unit control box, connect to power terminal block (see Power Wiring section on page 21).

Low-voltage wiring must be run in watertight conduit from the basepan to control box and through 7/8-in. diameter hole provided in bottom of unit control box. Field-supplied strain relief must be used going into the box. After wiring is in control box, make connections to proper terminals on terminal blocks (see Field Control Wiring section on page 23).

Routing Through Side of Unit — Route power wiring in field-supplied watertight conduit into unit through 2¹/₂-in. (sizes 020-035) or 3-in. (sizes 040-060 units) hole.

Use field-supplied strain relief going into control box through 3⁵/₈-in. diameter hole provided. After wires are in unit control box, connect to power terminal block (see Power Wiring section on page 21).

Bring low-voltage control wiring through the 7/8-in. diameter hole provided in the condenser section side post. Use strain relief going into 7/8-in. diameter hole in bottom of unit control box.

After wiring is in control box, make connection to proper terminals on terminal blocks (see Field Control Wiring section on page 23).

Affix crankcase heater sticker (located in the installer's packet) to unit disconnect switch.

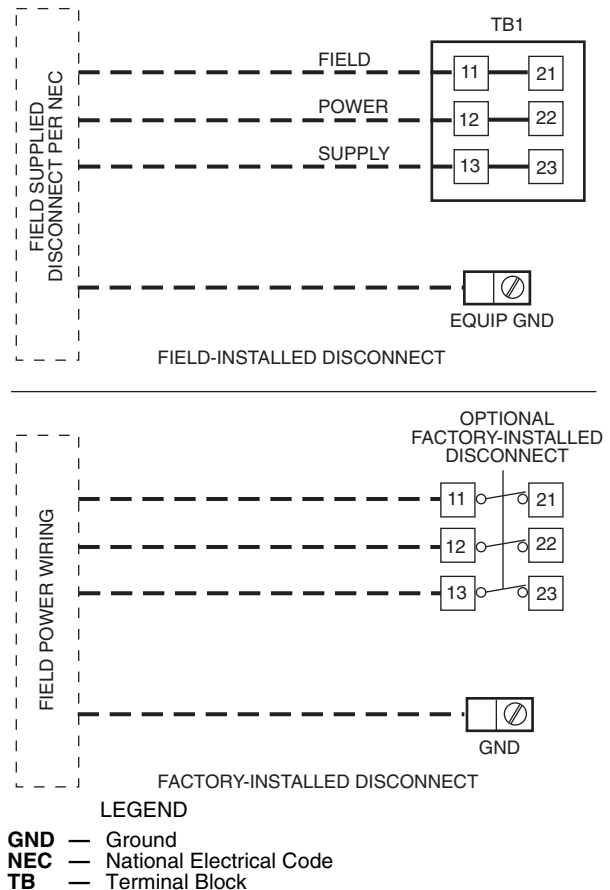

Fig. 20 — Field Power Wiring Connections

IMPORTANT: The variable air volume units use variable frequency drives, which generate and can radiate radio frequency energy. If units are not installed and used in accordance with these instructions, they may cause radio interference. They have been tested and found to comply with limits of a Class A computing device pursuant to International Standard in North American FN 61000-2/3, which are designed to provide reasonable protection against such interference when operated in a commercial environment.

⚠ WARNING

The unit must be electrically grounded in accordance with local codes and NEC ANSI/NFPA 70 (National Fire Protection Association). Failure to ground unit could cause personal injury.

Voltage to compressor terminals during compressor operation must be within the voltage range indicated on the unit nameplate. Phases must be balanced within 2%.

Use the following formula to determine the percent of voltage imbalance.

$$\% \text{ Voltage Imbalance} = 100 \times \frac{\text{max voltage deviation from average voltage}}{\text{average voltage}}$$

Example: Supply voltage is 230-3-60

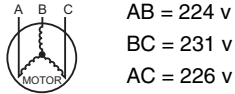

$$\text{Average Voltage} = \frac{(224 + 231 + 226)}{3} = \frac{681}{3} = 227$$

Determine maximum deviation from average voltage.

(AB) 227-224 = 3 v

(BC) 231-227 = 4 v

(AC) 227-226 = 1 v

Maximum deviation is 4 v.

Determine percent of voltage imbalance.

$$\% \text{ Voltage Imbalance} = 100 \times \frac{4}{227} = 1.78\%$$

This amount of phase imbalance is satisfactory as it is below the maximum allowable 2%.

IMPORTANT: If the supply voltage phase imbalance is more than 2%, contact your local electric utility company immediately.

NOTE: Check all factory and field electrical connections for tightness. Unit failure as a result of operation on improper line voltage or excessive phase imbalance constitutes abuse and may cause damage to electrical components.

IMPORTANT: On 208/230-v units, transformers 1 to 5 are wired for 230-v. If 208/230-v unit is to be run with 208-v power supply, the transformers must be rewired as follows:

For transformer 1 move the black wire connected to terminal H2 and connect it to terminal H3.

For transformers 2 to 4, used for the 24 volt control circuits, connect as follows:

1. Remove cap from red (208 v) wire.
2. Remove cap from spliced orange (230 v) wire. Disconnect orange wire from black unit power wire.
3. Cap orange wire.
4. Splice red wire and black unit power wire. Cap wires.

If the unit is equipped with the optional convenience outlet, connect the yellow wire to H2 on transformer 5.

IMPORTANT: BE CERTAIN UNUSED WIRES ARE CAPPED. Failure to do so may damage the transformers.

FIELD CONTROL WIRING — The 50A Series units support a large number of control options that can impact the field control wiring. Refer to Fig. 21 and 22.

The control options that the unit can provide relate to the following parameters:

- CV (constant volume), VAV (variable air volume), SAV (staged air volume), or VVT® (variable volume and variable temperature) control operation
- Standalone with a thermostat (CV) or with a space sensor (CV and VAV)
- Network application with CCN (Carrier Comfort Network®) or other networks
- Demand controlled ventilation with CO₂ sensor
- Economizer and economizer with changeover control
- Building and duct static pressure control
- Fire shutdown and smoke control

- Diagnostics and monitoring
- For constant volume applications a thermostat (T-Stat) or space temperature sensor (SPT) will be required.

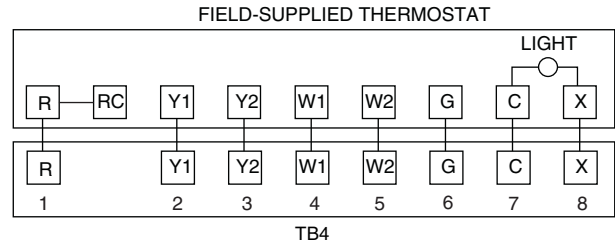

Fig. 21 — Field Control Thermostat Wiring

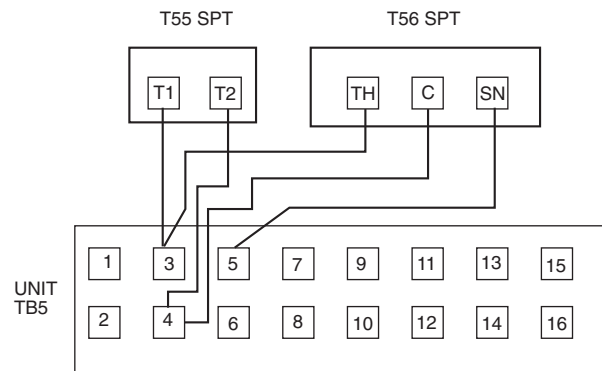

Fig. 22 — Space Temperature Sensor Wiring

T-STAT (Conventional Thermostat) — Unit can be controlled with a Carrier-approved accessory electro-mechanical or electronic thermostat that has two stages of cooling, two stages of heating control, and an output for indoor fan control. It may also include time of day scheduling or use the scheduling routines built into the *ComfortLink* controls.

Install thermostat according to the installation instructions included with accessory thermostat. Locate thermostat assembly on a solid interior wall in the conditioned space to sense average temperature.

Route thermostat cable or equivalent single leads of colored wire from subbase terminals through conduit into unit to low voltage connection in the main control box, as shown in Fig. 21 and 22. For thermostat TB4 connections see Fig. 21.

NOTE: For wire runs up to 50 ft, use no. 18 AWG (American Wire Gage) insulated wire (35 C minimum). For 50 to 75 ft, use no. 16 AWG insulated wire (35 C minimum). For over 75 ft, use no. 14 AWG insulated wire (35 C minimum). All wire larger than no. 18 AWG cannot be directly connected at the thermostat and will require a junction box and splice at the thermostat. Set heat anticipator settings as follows:

UNIT SIZE 50A	STAGE 1 (W1) ON	STAGE 2 (W1 AND W2) ON
020-050	0.24	0.13
060	0.36	0.13

Settings may be changed slightly to provide a greater degree of comfort for a particular installation.

SPT (Space Temperature Sensor) — For constant volume applications the *ComfortLink* controls can also be used with T55 and T56 space temperature sensors that use a 10K thermistor. The T56 sensor also has the capability for a configurable temperature set point offset at the thermostat. For variable air volume applications only the T55 sensor can be used.

Install sensor according to the installation instructions included with accessory sensor. Locate sensor assembly on a solid interior wall in the conditioned space to sense average temperature.

Run wiring to the space sensor as shown in Fig. 22.

Note that when the remote sensor is used, the red jumper wires provided must be connected from TB4 terminal 4 to 5 and TB4 terminal 5 to 1.

Both the T55 and T56 have a CCN communications port and this should be wired to the CCN Communications TB3 board if it is desired to have access to the CCN system through the sensor. If more than one T55 sensor is being used and averaged, sensors must be wired in multiples of 4 or 9 as shown in Fig. 23.

T58 Communicating Thermostat — Carrier also has a fully communicating thermostat which, if used, will be wired to the CCN communication connections on TB3 as described in the Carrier Comfort Network® Interface section below.

Carrier Comfort Network (CCN) Interface — The rooftop units can be connected to the CCN system. The communication bus wiring is supplied and installed in the field. Wiring consists of shielded, 3-conductor cable with drain wire. The system elements are connected to the communication bus in a daisy chain arrangement. The positive pin of each system element communication connector must be wired to the positive pins of the system element on either side of it, the negative pins must be wired to the negative pins, and the signal pins must be wired to signal ground pins. Wiring connections for CCN system should be made at the TB3 terminal block using the screw terminals. The TB3 board also contains an RJ14 CCN plug that can be used to connect a field service computer or other CCN device. There is also an RJ14 LEN (local equipment network) connection that is used to connect a Navigator™ display or download software.

Conductors and drain wire must be 20 AWG minimum stranded, tinned copper. Individual conductors must be insulated with PVC, PVC/nylon, vinyl, Teflon¹, or polyethylene. An aluminum/polyester 100% foil shield and an outer jacket of PVC, PVC/nylon, chrome vinyl, or Teflon with a minimum operating temperature range of -4°F to 140°F is required. Table 7 lists cables that meet the requirements.

Table 7 — CCN Connection Approved Shield Cable

MANUFACTURER	CABLE PART NO.
ALPHA	2413 or 5463
AMERICAN	A22503
BELDEN	8772
COLUMBIA	02525

IMPORTANT: When connecting the CCN communication bus to system elements, use color coding system for the entire network to simplify installation and checkout. See Table 8.

1. Teflon is a registered trademark of DuPont.

Table 8 — Color Code Recommendations

SIGNAL TYPE	CCN BUS CONDUCTOR INSULATION COLOR	CCN PLUG PIN NO.
POSITIVE (+)	RED	1
GROUND	WHITE	2
NEGATIVE (-)	BLACK	3

If a cable with a different color scheme is selected, a similar color code should be adopted for the entire network. At each system element, the shields of the communication bus cables must be tied together. If the communication bus is entirely within one building, the resulting continuous shield must be connected to a ground at one point only. If the communication bus cable exits from one building and enters another, the shields must be connected to grounds at the lightning suppressor in each building where the cable enters or exits the building (one point per building only).

To connect the unit to the network:

1. Turn off power to the control box.
2. Cut the CCN wire and strip the ends of the red (+), white (ground), and black (-) conductors. (If a different network color scheme is used, substitute appropriate colors.)
3. Remove the 3-pin male plug from the base control board in the main control box, and connect the wires as follows:
 - a. Insert and secure the red (+) wire to terminal 1 of the 3-pin plug.
 - b. Insert and secure the white (ground) wire to terminal 2 of the 3-pin plug.
 - c. Insert and secure the black (-) wire to terminal 3 of the 3-pin plug.
4. Insert the plug into the existing 3-pin mating connector on the base module in the main control box.

VAV Units with Heat — For variable air volume units that will use heat, the variable air volume terminals should be interlocked with the unit at TB5 terminals 1 and 2 as shown on the wiring diagram.

Demand Ventilation — The unit can be equipped with a CO₂ sensor for use in demand ventilation. This can be factory supplied and will be mounted in the return duct. It can also be field supplied and mounted in the return duct or in the space. Connect the field-installed 4 to 20 mA sensor to TB5 terminals 6 and 7. Do not remove the factory-installed 182-ohm resistor.

If an outdoor IAQ (indoor air quality) sensor is used then it should be wired to terminals 11 and 12 on TB6. This will require the use of the optional controls expansion module.

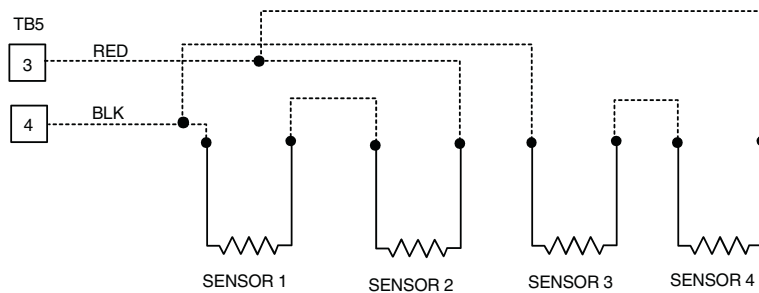

SPACE TEMPERATURE AVERAGING (4 SENSOR APPLICATION)

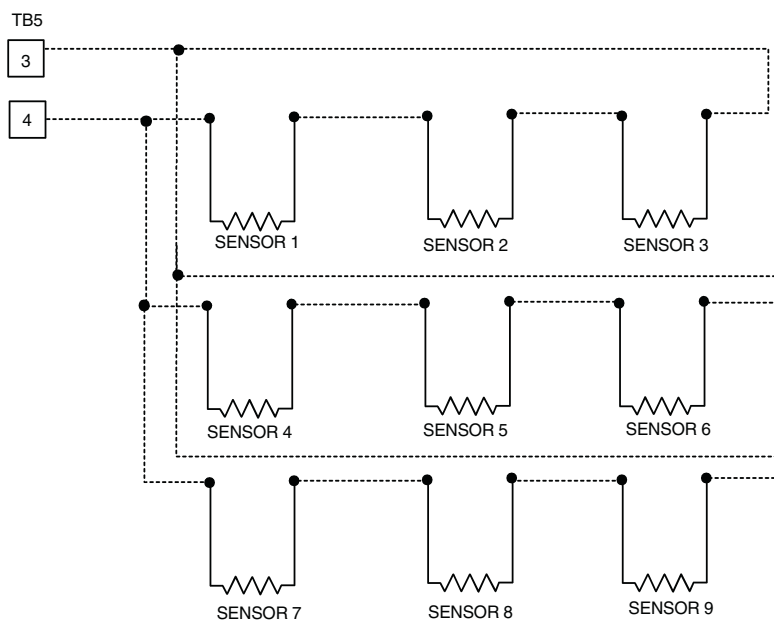

SPACE TEMPERATURE AVERAGING (9 SENSOR APPLICATION)

NOTE: Use T55 sensor only.

Fig. 23 — Space Temperature Averaging Wiring

Remote IAQ Override — If the control is being used with non-Carrier building management system, it supports the use of the remote IAQ override switch. This should be connected to TB6 terminal 13 and 14. Use of this will require the optional controls expansion module.

Remote Economizer Position Control — The *ComfortLink* controller will normally control the position of the economizer, but it can also support field control of the economizer position through a 4 to 20 mA signal. If this is used it should be connected to TB5 terminal 6 and 7. If the signal is a 4 to 20 mA signal, then leave the 182-ohm resistor in place.

Remote Economizer Minimum Position Control — If the *ComfortLink* controller is controlling the economizer but a remote minimum position is required, then an external 100K potentiometer should be connected to TB5 terminal 6 and 7. Remove the factory-installed 182-ohm resistor.

Remote Economizer Enable — If the control is being used with other building management systems and the system will control the enabling and disabling of the economizer free cooling, this switch input can be connected to TB6 terminals 1 and 2. Note that the controls also support integrated economizer changeover using outdoor dry bulb, differential dry bulb, outdoor enthalpy, and differential enthalpy.

Remote Occupancy Switch — For interface to other building management systems the control also supports a switch input

for remote occupancy signals. This wiring can be connected to terminal TB6 terminal 1 and 3.

Smoke Sensor Interface — The *ComfortLink* controls include an optional factory-installed return air smoke detector. Remote alarm circuits can be wired to TB5 terminal 8 and 9.

Fire Shutdown and Smoke Control — The control supports interface to fire and smoke control systems and allows for the following system overrides from remote switch inputs.

- Fire Shutdown — Connect to TB5 terminals 10 and 11.
- Smoke Pressurization — Connect to TB5 terminal 12 and 13. This requires the use of the optional controls expansion module.
- Smoke Evacuation — Connect to TB5 terminal 12 and 14. This requires the use of the optional controls expansion module.
- Smoke Purge — Connect to TB5 terminal 12 and 15. This requires the use of the optional controls expansion module.

Demand Limiting — The control can also be used with demand limiting control from remote building management systems. If a two-stage system is going to be used with redline limiting where the machine is not allowed to increase load and load shed where the load is decreased to a configurable limit in capacity then these can be connected to TB6 terminals 4 and 5 and 5 and 6. This requires use of the controls expansion module.

Step 7 — Make Outdoor-Air Inlet Adjustments

ECONOMIZER AND MIXED OUTDOOR AIR DAMPER — Hoods are used on all units with economizer or adjustable self-closing mixed outdoor air damper.

NOTE: If accessory power exhaust or barometric relief packages are being added to the unit, install power exhaust or barometric relief before installing economizer hoods.

Economizer Hood Assembly — The economizer hood is shipped in a package secured to the outside of the unit. The hood assemblies must be field-assembled. The 50A4,A5,A8,A9 units are side supply and side return. The return duct limits access to economizer filters from below.

The 50A020-050 units have two hoods on every unit. The 50A060 units have 3 hoods on every unit.

NOTE: Before assembly of the economizer hood, check along the outer edges of the economizer assembly for any seal strip protruding past the flanges. Trim the excess seal strip so that it is flush with the economizer assembly flanges.

Perform the following procedure to assemble the economizer hood.

1. Apply black seal strip (provided) to outside top-edge of hood sides. Wrap seal strip over edge to cover top flange (2 hood sides per hood assembly). Make sure seal strip covers screw holes. See Fig. 24.
 2. Add gray foam strip (provided) to cross members on bottom tray. See Fig. 25.
 3. Assemble hood sides, top, and cross member with gasketed screws provided. See Fig. 26.
 4. Attach speed clips (provided) to hood top. Engagement section of the clip faces inside hood. See Fig. 27.
 5. Apply black seal strip (provided) to mounting flanges of hood sides being sure to cover mounting holes. See Fig. 28.
 6. Apply black seal strip (provided) to back of hood top mounting flange. Seal strip of hood top mounting flange must press tightly against seal strip of hood side mounting flanges. See Fig. 28.
 7. Attach gray foam strip (provided) to block-off baffle on outer face of flange. See Fig. 29.
 8. Remove the screws on each end and along top of the outdoor air opening of unit. Set hood assembly in place and attach to unit using gasketed screws. See Fig. 30.
 9. Locate and mount block-off baffle using 3 screws. See Fig. 31.
 10. Assemble bottom filter tracks side by side with the mounting angle together. The filter track assemblies must be installed with the flange and mounting angle pointing down. See Fig. 32-34.
 11. Attach speed clips (provided) to hood side panels. Engagement section of clip faces up and towards the outside of the hood side panels. Attach mounting angles to hood with gasketed screws provided. See Fig. 35.
- NOTE:** Be sure the filters are installed with the airflow in the correct direction.
12. Attach filter track under the hood assembly. See Fig. 36.
 13. Attach black seal strip (provided) to filter cover. Seal strip should be applied centered over the holes of the one flange, making sure to fully cover holes and center over the other large flange. See Fig. 37.
 14. Slide two 20 x 25-in. filters into cross members of hood assembly. Attach filter cover over filters with screws and speed clips provided. See Fig. 38.

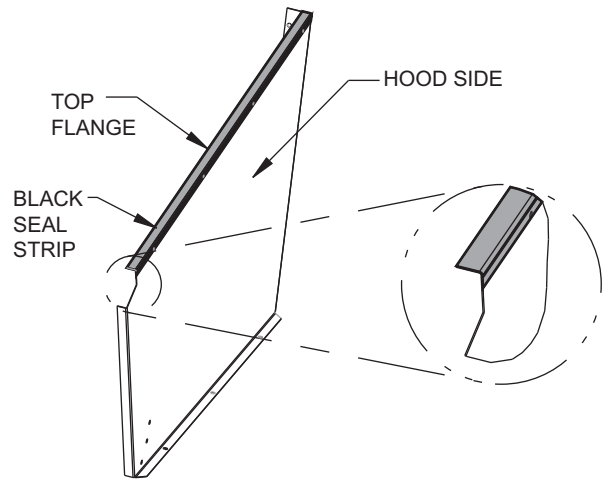

Fig. 24 — Adding Seal Strip to Top of Hood Sides

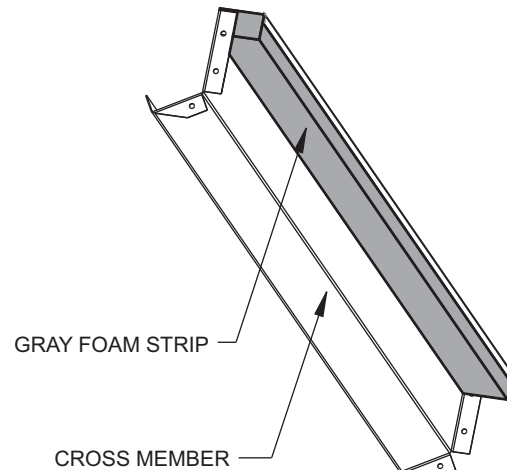

Fig. 25 — Adding Foam Strip to Cross Member

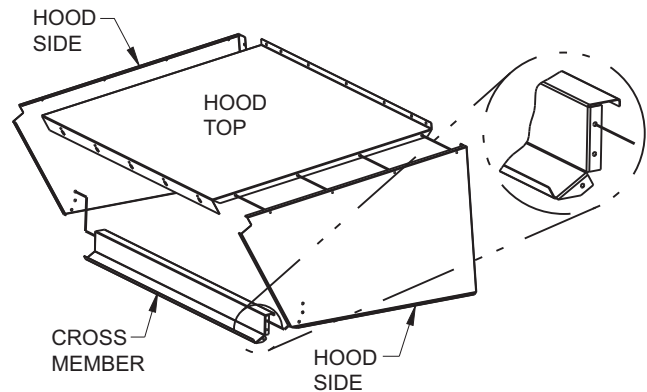

Fig. 26 — Economizer Hood Assembly

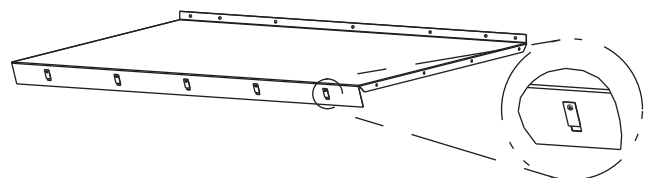

Fig. 27 — Top Hood with Speed Clips

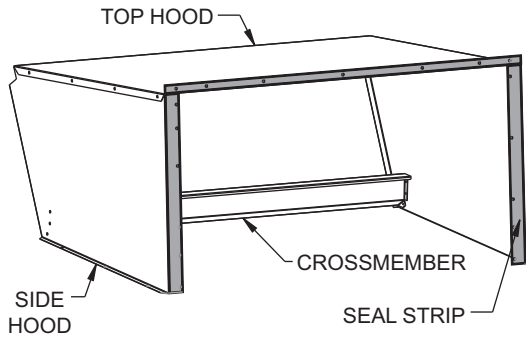

Fig. 28 — Adding Seal Strip to Hood Top and Side Hoods

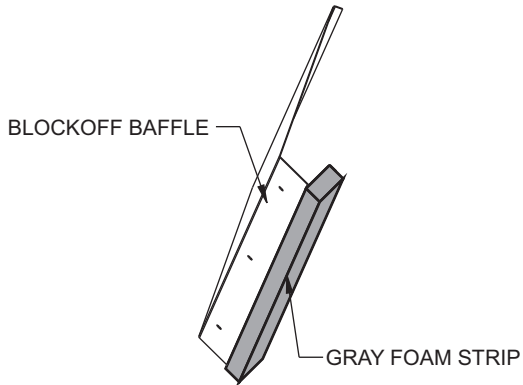

Fig. 29 — Adding Foam Strip to Block-Off Baffle

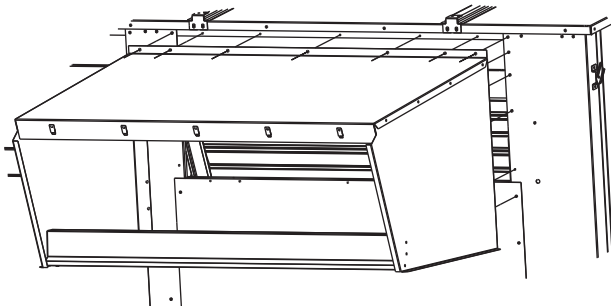

Fig. 30 — Removing Screws from the Outdoor Air Opening of Unit

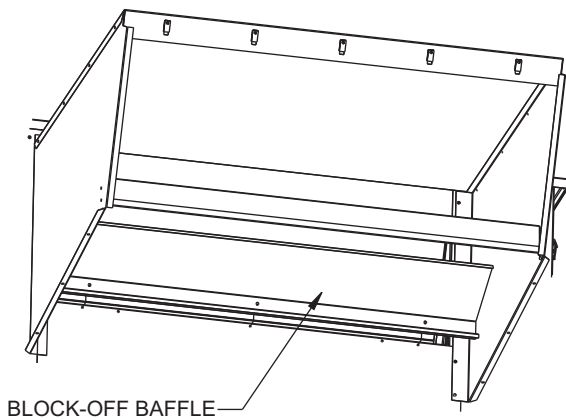

Fig. 31 — Mounting Block-Off Baffle to the Unit

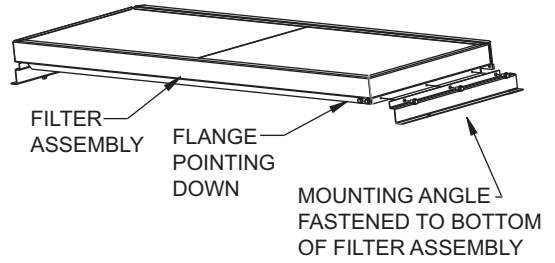

Fig. 32 — Correctly Assembled Bottom Filter Assembly, Sizes 020-035 Only

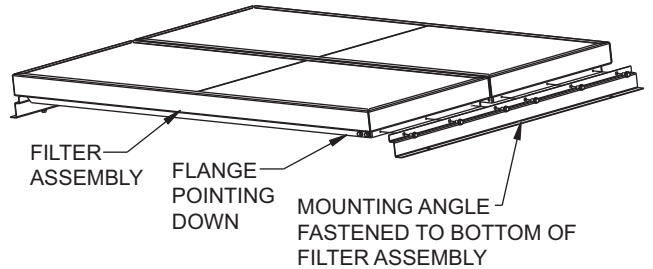

Fig. 33 — Correctly Assembled Bottom Filter Assembly, Sizes 040-060 Only

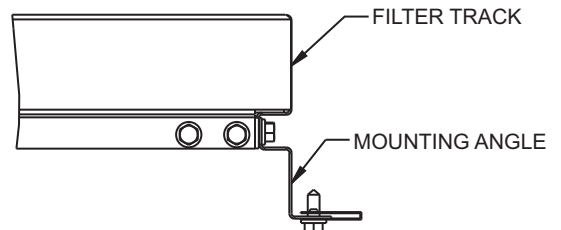

Fig. 34 — Flange and Mounting Angle Pointing Down

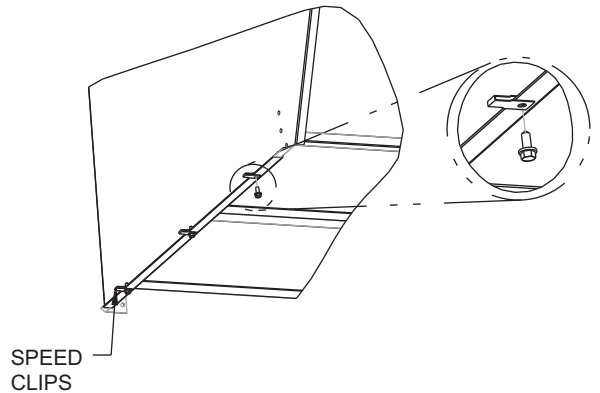

Fig. 35 — Bottom Filters Installed with Flange Pointing Down

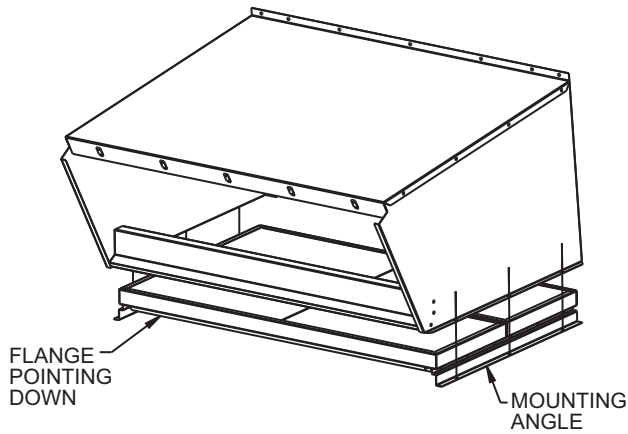

Fig. 36 — Bottom Filters Installed with Flange Pointing Down

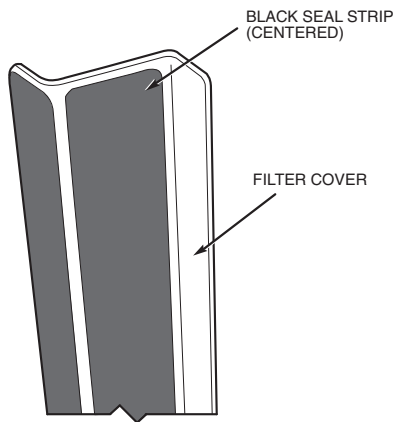

Fig. 37 — Attaching Seal Strip to Filter Cover

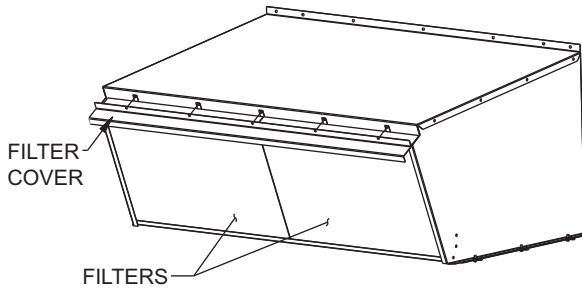

Fig. 38 — Slide Two Filters

Step 8 — Position Power Exhaust/Barometric Relief Damper Hood

— All units are shipped with the hoods folded inside the unit in a shipping position. For 50A2,A3,A6,A7 units the hood must be tilted out once the

unit is installed. On 50A4,A5,A8,A9 units (designed for horizontal supply and return), the assemblies will have to be relocated to return ductwork. See Fig. 39 for dimensions and details.

All electrical connections have been made and adjusted at the factory. The power exhaust blowers and barometric relief dampers are shipped assembled and tilted back into the unit for shipping. Brackets and extra screws are shipped in shrink wrap around the dampers. If ordered, each unit will have 4 (50A020-050 units) or 6 (50A060 units) power exhaust blowers and motors or barometric relief dampers.

1. Remove 9 screws holding each damper assembly in place. See Fig. 40. Each damper assembly is secured with 3 screws on each side and 3 screws along the bottom. Save screws.

CAUTION

Be careful when tilting blower assembly. Hoods and blowers are heavy and can cause injury if dropped.

2. Pivot each damper assembly outward until edges of damper assembly rest against inside wall of unit.
3. Secure each damper assembly to unit with 6 screws across top (3 screws provided) and bottom (3 screws from Step 1) of damper.
4. With screws saved from Step 1, install brackets on each side of damper assembly.
5. Remove tape from damper blades.

Step 9 — Route Static Pressure Sensors

VAV DUCT PRESSURE TRANSDUCER — The VAV duct pressure transducer (VAV inverter pressure transducer) is located behind the filter access door on the lower inner panel. See Fig. 41. A section of field-supplied 1/4-in. plastic tubing must be run from the high pressure tap on the differential pressure switch and connected to a field-supplied tap in the supply-air duct. The tap is usually located 2/3 of the way out on the main supply duct. Remove plug button in panel to route tubing.

BUILDING PRESSURE TRANSDUCER — The building pressure transducer (modulating power exhaust pressure transducer) is located behind the filter access door on the lower inner panel. See Fig. 41. A section of field-supplied 1/4-in. plastic tubing must be run from the high-pressure tap on the differential pressure switch to the conditioned space. The pressure tube must be terminated in the conditioned space where a constant pressure is required. This location is usually in an entrance lobby so that the building exterior doors will open and close properly. Remove plug button in panel to route tubing.

The low pressure tap is factory-routed to the atmosphere. For a positive-pressure building, route the high tap to building air and low tap to atmosphere. For a negative-pressure building, route the high tap to atmosphere and the low tap to building air.

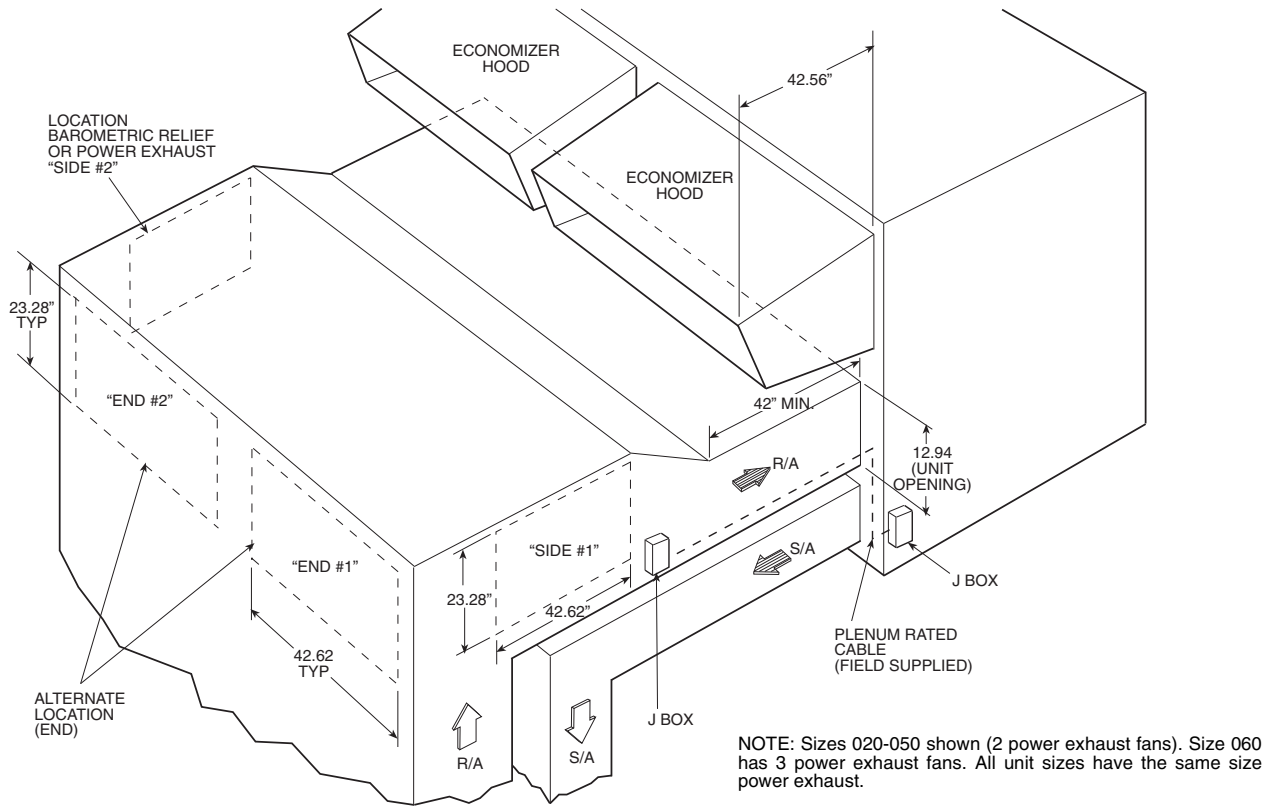
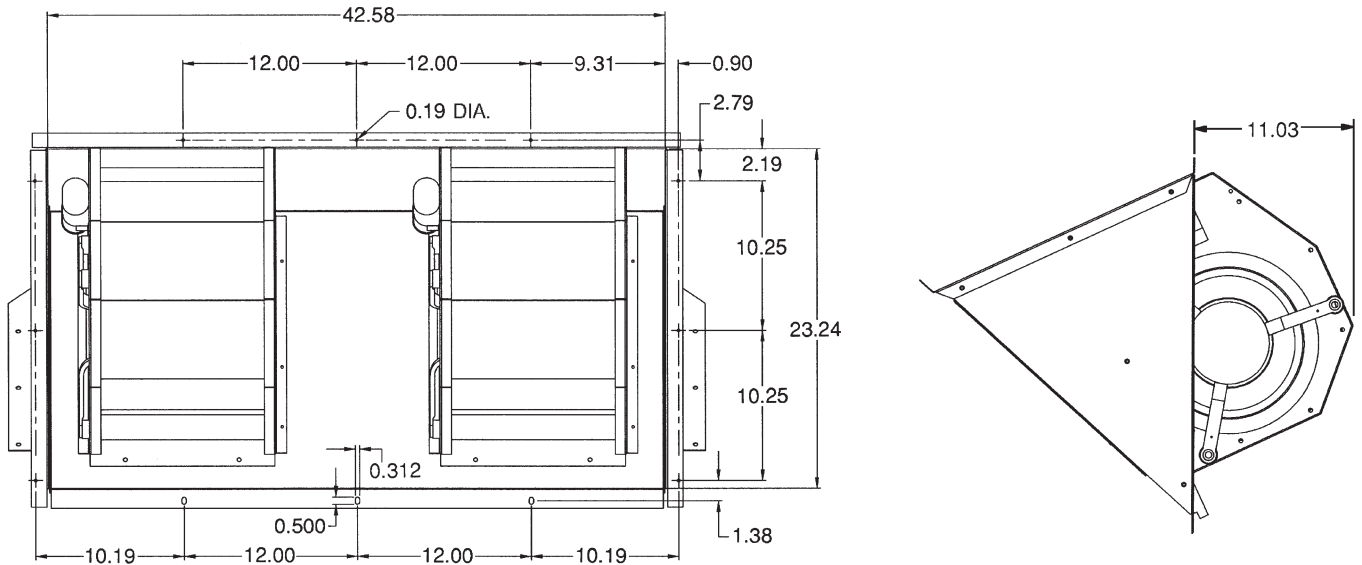

Fig. 39 — Side Return Air Conversion (for CRPWREXH033A00, 034A00, 035A00, and 036A00)



NOTES:

1. Unless otherwise specified, all dimensions are to outside of part.
2. Dimensions are in inches.
3. On 50A4,A5,A8,A9 units, accessory barometric relief or power exhaust must be mounted in the field-supplied return ductwork.

Fig. 40 — Barometric Relief Damper and Power Exhaust Mounting Details (for CRPWREXH033A00, 034A00, 035A00, and 036A00)

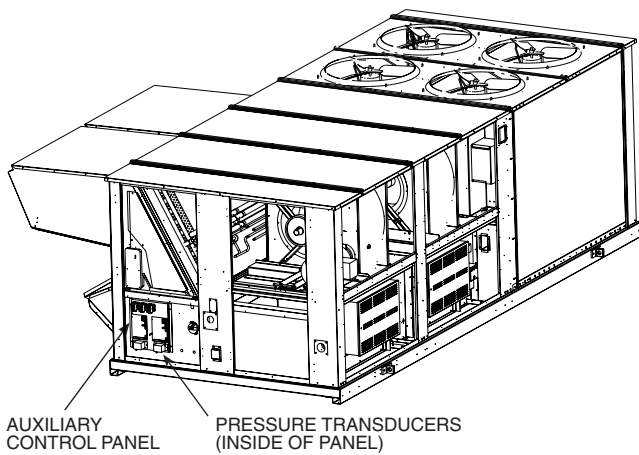

Fig. 41 — Pressure Transducer Locations

Step 10 — Install All Accessories/Options — After all the factory-installed options have been adjusted, install all field-installed accessories. Refer to the accessory installation instructions included with each accessory.

The 50A Series units have a large number of factory-installed options which were previously available only as accessories. Some of the available options can also be installed in the field if needed. In most cases the units have been pre-wired so that the accessories can be easily installed. Instructions are shipped with each accessory. Configuration of the controls for these accessories as well as the factory-installed options can be found in the Controls, Start-up, Operation, Service and Troubleshooting book. The following is a list of some of the common accessories:

- Thermostats and space temperature sensors
- Accessory barometric relief damper
- Accessory power exhaust
- Non-modulating to modulating power exhaust
- Condenser coil hail guards
- Outdoor humidity sensor (used for economizer enthalpy changeover)

- Return air humidity sensors (used for economizer differential enthalpy changeover, factory-installed with Humidi-MiZer option)
- Return air smoke detector
- Controls expansion module (used for interface to building management systems, not typically needed on system with Carrier Comfort Network® [CCN] devices)
- Plugged filter sensor
- Motormaster® V low ambient head pressure control

FIELD-FABRICATED WIND BAFFLES

IMPORTANT: Carrier recommends the installation of field-fabricated wind baffles on all vertically oriented condenser coils when operating in environments with prevailing winds of more than 5 mph and where temperatures drop below 32°F. See the Motormaster accessory installation guide for instructions.

⚠ WARNING

To avoid the possibility of electrical shock, open all disconnects before installing or servicing this accessory.

In areas with prevailing winds of more than 5 mph and where temperatures drop below 32°F, wind baffles must be field fabricated to ensure proper cooling cycle operation at low-ambient temperatures with Motormaster V controls. Baffles are not needed on size 060 units with MCHX (microchannel heat exchangers). See Fig. 42 for baffle details. Use 20-gage galvanized sheet metal, or similar corrosion-resistant material for the baffles. Use field-supplied screws to attach baffles to unit. Screws should be 1/4-in. diameter or larger. Screws should not be more than 1/2 inch in length. Drill required screw holes for mounting baffles.

⚠ CAUTION

To avoid damage to refrigerant coils, electrical components, and wiring use extreme care when drilling screw holes and screwing in fasteners.

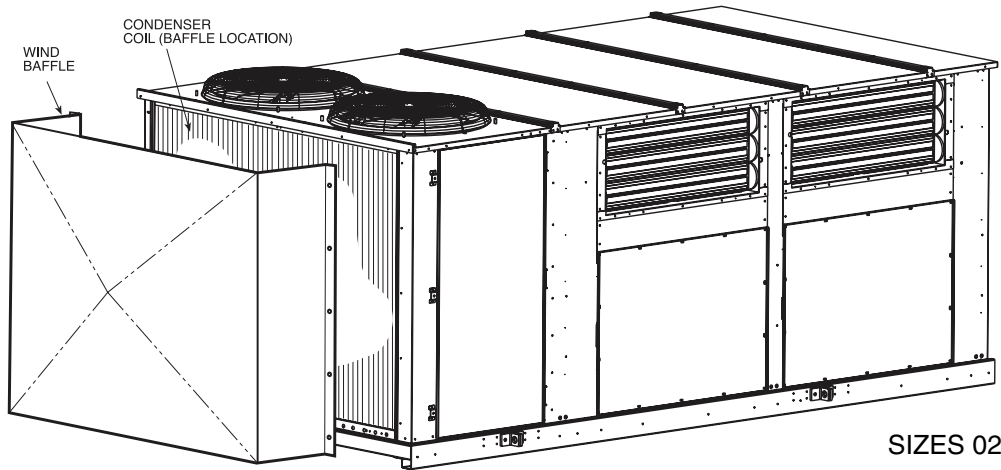

SIZES 020-035

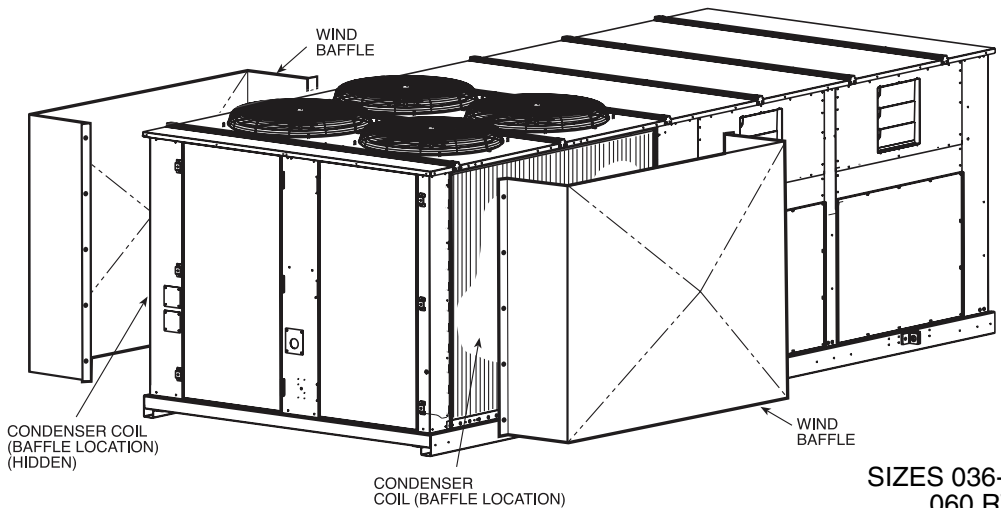

SIZES 036-050 AND 060 RTPF

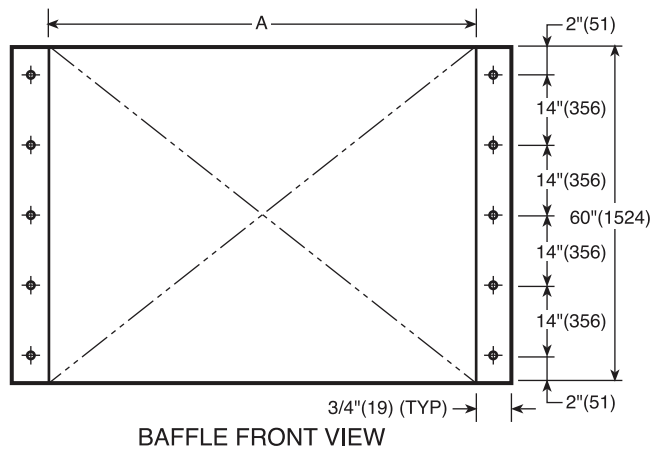
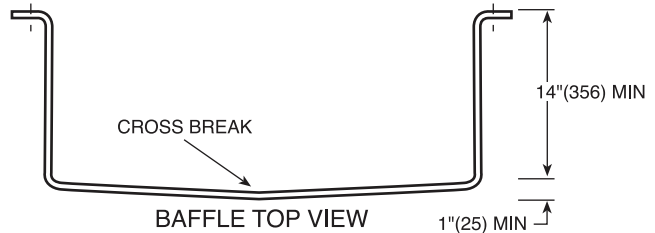

UNIT SIZE 50A	QUANTITY	DIMENSION "A"	
		IN.	MM
020-035	1	78.125 ± 0.125	1984 ± 3
036-050	2	78.125 ± 0.125	1984 ± 3
060	2	118 ± 0.125	2997 ± 3

NOTE: 50A060 units with MCHX do not require baffles.

LEGEND
MCHX — Microchannel Heat Exchanger
RTPF — Round Tube Plate Fin Heat Exchanger

Fig. 42 — Wind Baffle Details

Step 11 — Perform Field Modifications

DUCTWORK

Bottom Return Units (50A2,A3,A6,A7) Field-Modified for Side Return — The 50A2,A3,A6,A7 units with bottom return air connections may be field-modified to accommodate side return air connections.

IMPORTANT: The following section is a guideline and not a comprehensive procedure to field modify the units. The installing contractor must provide some design initiative. Field conversion is complex and is not recommended. Units with electric heat must not be converted because of potential heating mode operating problems.

Conversion to horizontal return requires that the bottom return openings of the unit must be sealed with airtight panels capable of supporting the weight of a person. The return ductwork connection locations on the side of the unit are higher than normal (31 in. high). Unit-mounted power exhaust or barometric relief cannot be used because return air ductwork will cover the power exhaust or barometric relief installation locations. Power exhaust or barometric relief may be installed in the return air ductwork.

To convert the unit, perform the following:

1. Seal the bottom return openings of the unit with airtight panels capable of supporting the weight of a person.
2. Remove the panels located below the economizer outdoor-air dampers. These openings will be used for the return-air ductwork. There are 2 panels on 50A3,A6,A7020-050 units. There are 3 panels on 50A2,A3,A6,A7060 units. These openings are normally used for power exhaust or barometric relief.
3. Run the return air ductwork up to the openings. One single duct is recommended to connect to the unit over the return air openings. See Fig. 43. The return duct must incorporate a minimum $\frac{3}{4}$ -in. flange for connection to the unit cabinet. The unit does not have duct flanges for this conversion.

Side Supply and Return Units (50A4,A5,A8,A9) with Field-Installed Power Exhaust in Return Duct — Space must be available in the return duct to mount the power exhaust fan (gravity relief) modules. Dimensions and suggested locations are shown in Fig. 43. These instructions are a guideline and not a comprehensive procedure. The design contractor must provide some design initiative.

The wiring harness that is provided with the power exhaust accessory is not long enough for the fan modules to be mounted in the return air duct. Field-supplied wiring must be spliced into the harness. Use a junction box at each splice. The wiring may be run in the return duct as shown in Fig. 43 or externally in conduit. A service access panel will be needed near each power exhaust fan.

BACnet¹ Communication Option Wiring

WIRING THE UPC OPEN CONTROLLER TO THE MS/TP NETWORK — The UPC Open controller communicates using BACnet on an MS/TP network segment communications at 9600 bps, 19.2 kbps, 38.4 kbps, or 76.8 kbps.

Wire the controllers on an MS/TP network segment in a daisy-chain configuration. Wire specifications for the cable are 22 AWG (American Wire Gage) or 24 AWG, low-capacitance, twisted, stranded, shielded copper wire. The maximum length is 2000 ft.

Install a BT485 terminator on the first and last controller on a network segment to add bias and prevent signal distortions due to echoing. See Fig. 44-46.

To wire the UPC Open controller to the BAS network:

1. Pull the screw terminal connector from the controller's BAS Port.
2. Check the communications wiring for shorts and grounds.
3. Connect the communications wiring to the BAS port's screw terminals labeled Net +, Net -, and Shield.

NOTE: Use the same polarity throughout the network segment.

4. Insert the power screw terminal connector into the UPC Open controller's power terminals if they are not currently connected.
5. Verify communication with the network by viewing a module status report. To perform a module status report using the BACview² keypad/display unit, press and hold the "FN" key then press the "." key.

To install a BT485 terminator, push the BT485 terminator on to the BT485 connector located near the BACnet connector.

NOTE: The BT485 terminator has no polarity associated with it.

To order a BT485 terminator, consult Commercial Products i-Vu[®] Open Control System Master Prices.

MS/TP WIRING RECOMMENDATIONS — Recommendations are shown in Tables 9 and 10. The wire jacket and UL temperature rating specifications list two acceptable alternatives. The Halar³ specification has a higher temperature rating and a tougher outer jacket than the SmokeGard⁴ specification, and it is appropriate for use in applications where the user is concerned about abrasion. The Halar jacket is also less likely to crack in extremely low temperatures.

NOTE: Use the specified type of wire and cable for maximum signal integrity.

-
1. BACnet is a registered trademark of ASHRAE (American Society of Heating, Refrigerating, and Air-Conditioning Engineers).
 2. BACview is a registered trademark of Automated Logic Corporation.
 3. Halar is a registered trademark of Solvay Plastics.
 4. SmokeGard is a trademark of AlphaGary-Mexichem Corp.

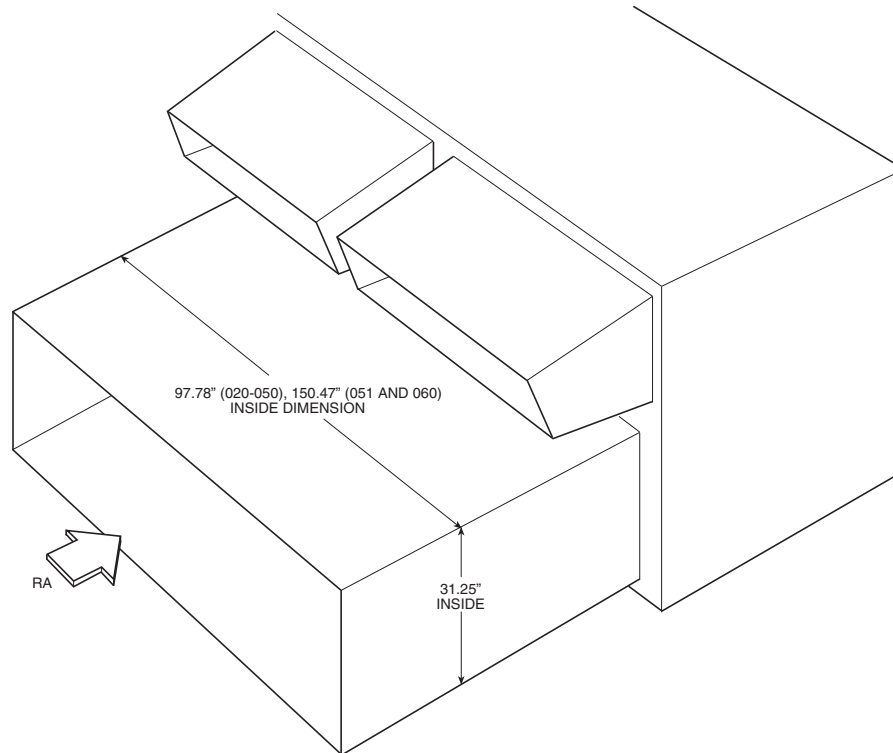

Fig. 43 — Side Return Duct Dimensions

Table 9 — Open System Wiring Specifications and Recommended Vendors

WIRING SPECIFICATIONS		RECOMMENDED VENDORS AND PART NUMBERS			
WIRE TYPE	DESCRIPTION	CONNECT AIR INTERNATIONAL	BELDEN	RMCORP	CONTRACTORS WIRE AND CABLE
MS/TP NETWORK (RS-485)	22 AWG, single twisted shielded pair, low capacitance, CL2P, TC foam FEP, plenum rated. See MS/TP Installation Guide for specifications.	W221P-22227	—	25160PV	CLP0520LC
	24 AWG, single twisted shielded pair, low capacitance, CL2P, TC foam FEP, plenum rated. See MS/TP Installation Guide for specifications.	W241P-2000F	82841	25120-OR	—
RNET	4 conductor, unshielded, CMP, 18 AWG, plenum rated.	W184C-2099BLB	6302UE	21450	CLP0442

LEGEND

- AWG** — American Wire Gage
- CL2P** — Class 2 Plenum Cable
- CMP** — Communications Plenum Rated
- FEP** — Fluorinated Ethylene Polymer
- TC** — Tinned Copper

Table 10 — MS/TP Wiring Recommendations

SPECIFICATION	RECOMMENDATION
CABLE	Single twisted pair, low capacitance, CL2P, 22 AWG (7x30), TC foam FEP, plenum rated cable
CONDUCTOR	22 or 24 AWG stranded copper (tin plated)
INSULATION	Foamed FEP 0.015 in. (0.381 mm) wall 0.060 in. (1.524 mm) O.D.
COLOR CODE	Black/White
TWIST LAY	2 in. (50.8 mm) lay on pair 6 twists/foot (20 twists/meter) nominal
SHIELDING	Aluminum/Mylar shield with 24 AWG TC drain wire
JACKET	SmokeGard Jacket (SmokeGard PVC) 0.021 in. (0.5334 mm) wall 0.175 in. (4.445 mm) O.D. Halar Jacket (E-CTFE) 0.010 in. (0.254 mm) wall 0.144 in. (3.6576 mm) O.D.
DC RESISTANCE	15.2 Ohms/1000 feet (50 Ohms/km) nominal
CAPACITANCE	12.5 pF/ft (41 pF/meter) nominal conductor to conductor
CHARACTERISTIC IMPEDANCE	100 Ohms nominal
WEIGHT	12 lb/1000 feet (17.9 kg/km)
UL TEMPERATURE RATING	SmokeGard 167°F (75°C) Halar -40 to 302°F (-40 to 150°C)
VOLTAGE	300 Vac, power limited
LISTING	UL: NEC CL2P, or better

LEGEND

- AWG** — American Wire Gage
- CL2P** — Class 2 Plenum Cable
- DC** — Direct Current
- FEP** — Fluorinated Ethylene Polymer
- NEC** — National Electrical Code
- O.D.** — Outside Diameter
- TC** — Tinned Copper
- UL** — Underwriters Laboratories

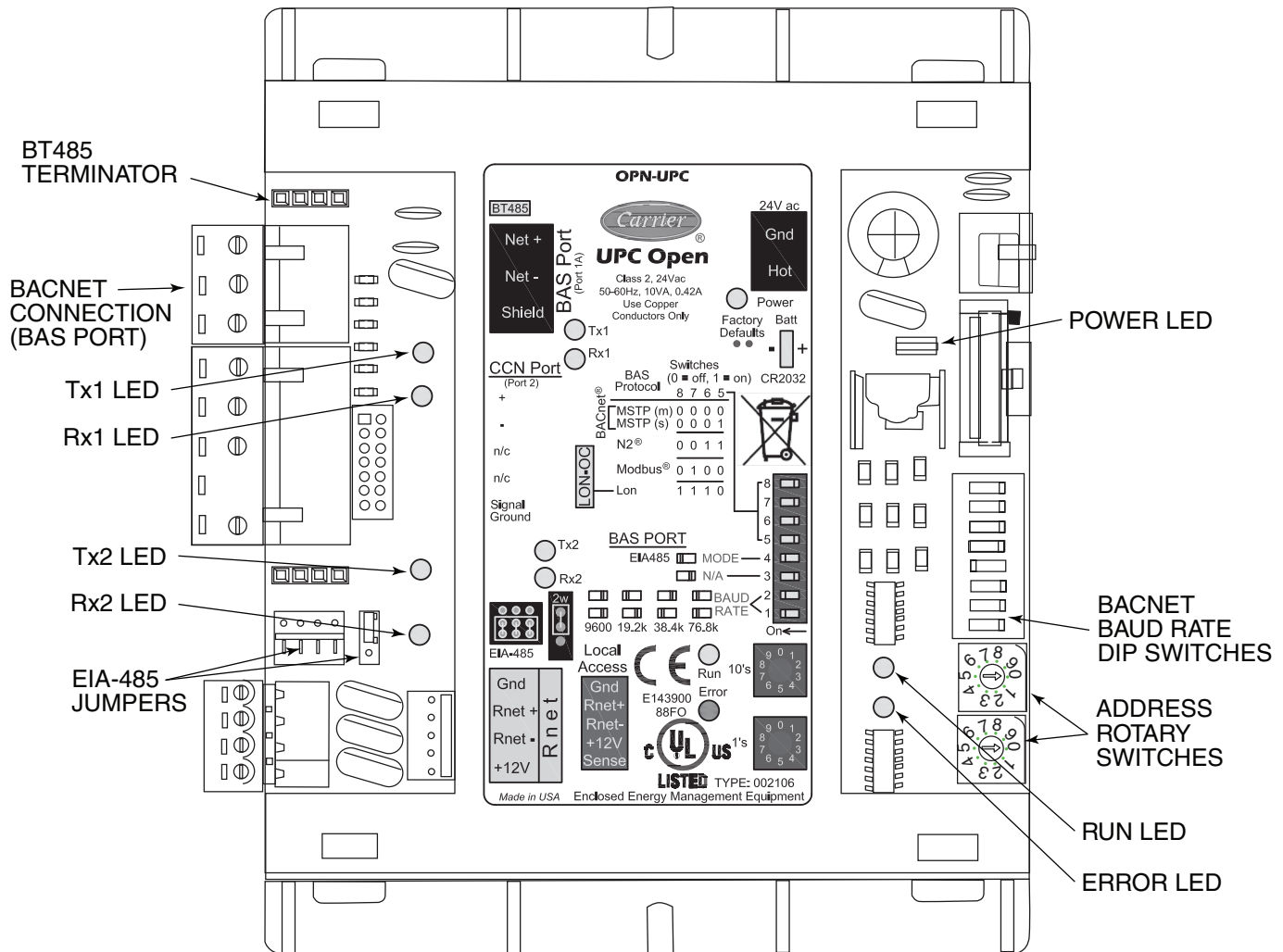

Fig. 44 — UPC Open Controller

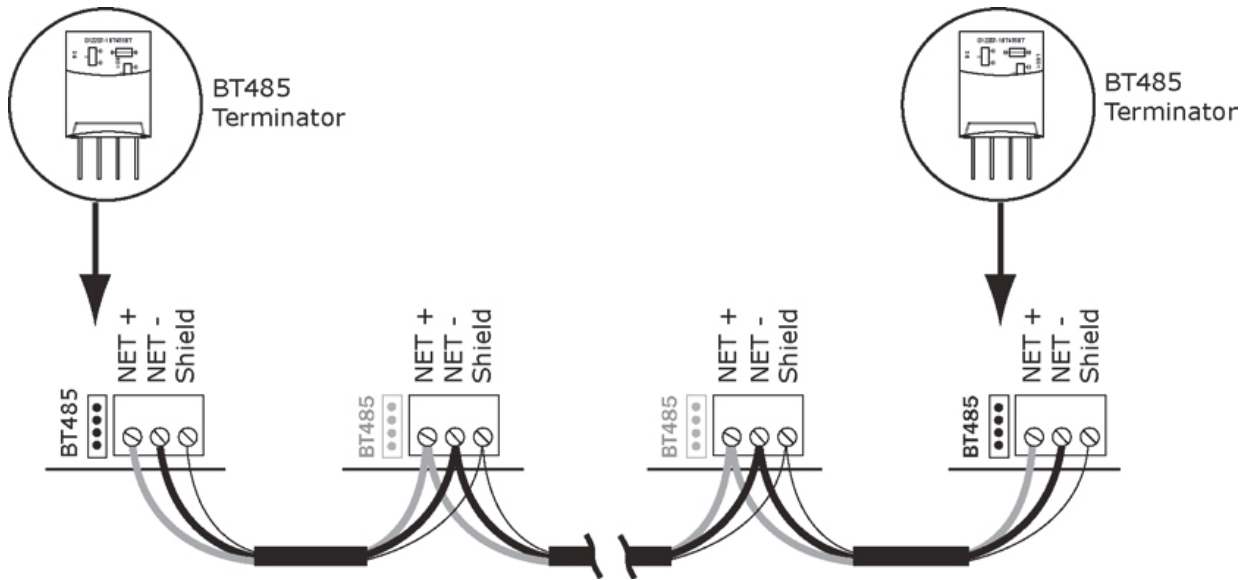

Fig. 45 — Open System Network Wiring

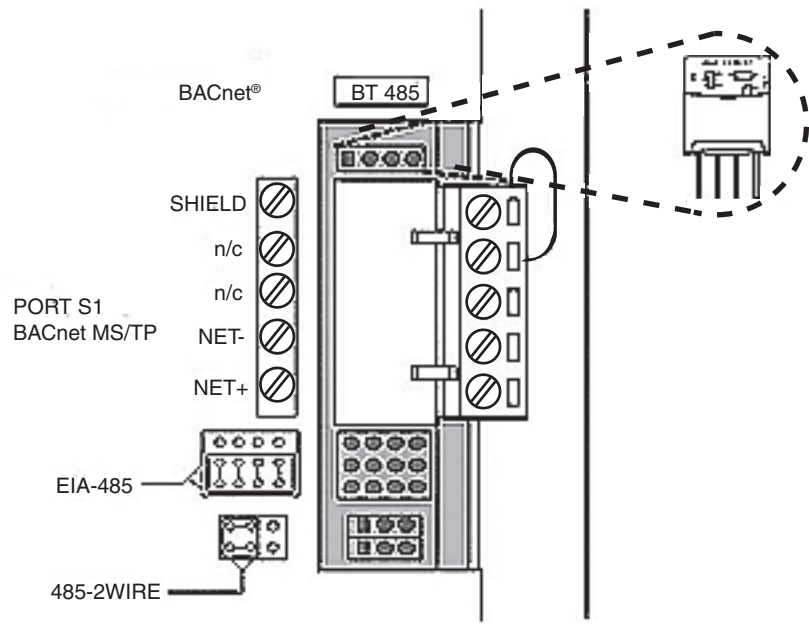

Fig. 46 — BT485 Terminator Installation

